

HiNRG Pool and Spa Heater Models 175, 250 and 400

ASTRALPOOL 

INSTALLATION AND OPERATING INSTRUCTIONS



Melbourne: 03 8796 8600
Sydney: 02 9853 2100
Brisbane: 07 3308 5400

Gold Coast: 07 5552 2600
Townsville: 07 4750 3100
Adelaide: 08 8152 7600

Perth: 08 9350 2600
sales@astralpool.com.au
www.astralpool.com.au

A division of
FLUIDRA



INDEX

INTRODUCTION		
	INTRODUCTION	3
	NOTICE TO INSTALLERS	3
	SAFETY RULES	3
	IMPORTANT SAFETY NOTE	4
OPERATION INSTRUCTIONS		
	OPERATION INSTRUCTIONS	4
	TO TURN GAS OFF TO APPLIANCE	4
	CHEMICAL BALANCE	5
	CORROSION PREVENTION IN HEATERS	5
	DIGITAL THERMOSTAT OPERATION	6
	DISPLAY SYMBOL INDICATION	7
MAINTENANCE		
	MAINTENANCE	8
	WINTER OPERATION	8
INSTALLATION		
	INSTALLATION INSTRUCTIONS	8
	FLOW RATES	8
	WATER CONNECTIONS	8
	PLUMBING DIAGRAM	9
	HEATER DIMENSIONS	9
	INDOOR FLUE INSTALLATION	10
	ROOF TERMINATIONS	13
	WALL TERMINATIONS	13
	CLEARANCES	14
	VENTILATION	14
	ELECTRICAL CONNECTION	15
	GAS CONNECTION	15
	WATER PRESSURE ADJUSTMENT	16
	TESTING GAS PRESSURE	17
BURNER PERFORMANCE DETAILS		
	PERFORMANCE DETAILS	18
TROUBLESHOOTING		
	FAULT FINDING AND REMEDIES	18
	IGNITION MODULE LED FLASH CODES	19
GAS PIPE SIZING		
	GAS PIPE SIZING CHART	20
WIRING DIAGRAM		
	HINRG SERIES WIRING DIAGRAM	21
POOL HEATER MAINTENANCE		
	MAINTENANCE SCHEDULE	22
	NOTES	23
WARRANTY		
	TERMS AND CONDITIONS	24

INTRODUCTION

Congratulations on your purchase of a HiNRG Pool and Spa Heater by Astral Pool. Proper installation and service of your new heating system and correct chemical maintenance of the water will ensure years of enjoyment. The HiNRG Series Heater is a compact lightweight and highly efficient gas fired pool and spa heater. It is equipped with features that take advantage of new technology to provide a user friendly, efficient and environmentally friendly pool or spa heater.

The HiNRG can safely be connected to PVC pipe. It accepts a wide range of water flow rates from as little as 120 litres per minute making it perfectly suitable for energy efficient variable speed pool and spa pumps. In addition, it is equipped with electronic start up and an accurate electronic thermostat to ensure ease of use and accurate temperature control. The electronic display shows at a glance the operational status of the heater.

 The appliance is not intended for use by young children or infirm person without supervision. Please ensure that young children are supervised to ensure that they do not play with the appliance.

NOTICE TO INSTALLERS

 This appliance must be installed by an authorized person.

This appliance must be installed in accordance with the installation instructions, local gas fitting regulations, Standards Australia Installation Code AS/NZ 5601 and any other relevant statutory authorities.

Refer to data plate for details of gas type, gas consumption and burner pressure.

For a heater in which no provision is made for a vent permanently open between the water circuit and atmosphere a pressure relief valve must be fitted in accordance with clause 2.8.7 of the Australian Standard for Gas Pool Heaters AS 4560-2004.

 **WARNING:** Electrical maintenance and repairs of this equipment must only be done by qualified persons in accordance with Australian and state regulations.

SAFETY RULES

1. Spa or hot tub water temperature should never exceed 40°C.
2. Drinking of alcoholic beverages before or during spa or hot tub use can cause drowsiness which could lead to unconsciousness and subsequently result in drowning.
3. Pregnant women beware! Soaking in water above 38°C during the first three months of pregnancy can cause foetal damage.
4. Before entering the spa or hot tub, the user should check the water temperature with an accurate thermometer, spa or hot tub thermostats may err in regulating water temperatures by as much as 2°C.
5. Persons with a medical history of heart disease, circulatory problems, diabetes or blood pressure problems should obtain their physician's advice before using spas or hot tubs.
6. Persons taking medications which induce drowsiness, such as tranquillisers, antihistamines or anticoagulants, should not use spas or hot tubs.

 **WARNING!** Should overheating occur or the gas supply fail to shut off, turn off the manual gas control valve to the appliance. Do not use this heater if any part has been under water.

FOR YOUR SAFETY – READ BEFORE LIGHTING

This appliance is equipped with an ignition device which automatically lights the burner. Do not try to light the burner by hand.

BEFORE OPERATING smell all around the appliance area for gas. Be sure to smell next to the floor because some gas is heavier than air and will settle on the floor.

 **WHAT TO DO IF YOU SMELL GAS.** Do not try to light any appliance. Do not touch any electrical switch. Do not use any telephone in your building. Immediately call your gas supplier from a neighbour's house.

 **DO NOT PLACE ARTICLES ON OR AGAINST THIS APPLIANCE**

 **DO NOT USE OR STORE FLAMMABLE MATERIALS NEAR THIS APPLIANCE**

 **DO NOT SPRAY AEROSOLS IN THE VICINITY OF THIS APPLIANCE WHILE IT IS IN OPERATION.**

 **NOTE – SERVICING SHALL BE CARRIED OUT ONLY BY AUTHORIZED PERSONNEL.**

OPERATING INSTRUCTIONS

1.  **STOP!** Read the safety information above.
2. Turn off electric power to appliance.
3. This appliance is equipped with an ignition device which automatically lights the burner. Do not try to light the burner by hand.
4. Wait five minutes to clear out any gas. If you then smell gas, STOP! Refer to instructions above.
5. Turn filtration pump on.
6. Ensure water is flowing through the heater.
7. Turn on power to the heater and press the pool/spa button to select pool or spa mode.
8. Set thermostat to desired setting and the ON/OFF switch to turn the heater ON.
9. The heater will ignite in 60 seconds.
10. If the appliance does not operate, turn heater power supply off. Repeat instructions 5 to 7 above. If the appliance still does not ignite, call your service technician.

TO TURN GAS OFF TO APPLIANCE

1. Turn off all electrical power to the appliance.
2. Turn off gas tap in gas line prior to heater.

CHEMICAL BALANCE

 It is imperative that correct chemical balance be maintained in your pool and spa water, otherwise corrosion of your heater may occur. **Corrosion of the heat exchanger voids warranty.** Your local pool shop specialist or spa retailer can advise correct chemical balance. Your water should be checked and maintained regularly by a pool water professional. As a guide the following parameters may be used.

pH	7.2 to 7.6
Total Alkalinity (ppm)	80 to 120
Calcium Hardness (ppm)	150 to 250
Salinity (ppm)	4000 max. Excessive salt can damage your heater

You should test your water chemical balance at least on a weekly basis.

Excessive sanitiser can damage your heater. Chlorine should not exceed 3 ppm and bromine should not exceed 5 ppm. Salt chlorinators, especially when used on spa pools or indoor or covered pools, can easily produce excessive chlorine levels which will damage the heater internals.

CORROSION PREVENTION IN HEATERS

All pool and spa heaters use copper or copper nickel to make their heat exchangers as it is the most efficient material in transferring heat from the combustion chamber into the water. The typical life expectancy of a well maintained pool/spa heater is between 5 and 12 years.

The addition of sanitisers (Chlorine, Bromine etc.) and other water balancing and conditioning chemicals can increase the rate of wear and tear on the heat exchanger and associated parts in your heater.

There are three most common reasons for heat exchanger corrosion which can be avoided with a little care and attention.

1. Excessive Sanitiser.

This means too much Chlorine or Bromine in the water. Be careful, if the level of Chlorine or Bromine is excessively high your test kit (and the pool shops) may not read accurately or indeed may show a nil reading. Any time a salt chlorinator is operating for extended periods, (when heating the swimming pool from cold), particularly if the weather is overcast or the pool enclosed or covered, the Chlorine level may exceed normal levels. When heating a Spa Pool, turn the chlorinator down or off for the duration of the heating period.

2. Out of balance water.

The water balance is a combination of pH, total alkalinity, Calcium hardness and temperature. Balanced water will help prevent corrosion of your heater. Balanced water should be between 7.2 - 7.6 pH.

3. The addition of acid to lower pH.

Acid must always be added in small quantities and spread over the pool surface evenly, not added in to the skimmer. Do not add a litre at a time, add a cup full each day to lower your pH.

 If you have a **salt chlorinated** INDOOR pool or COVERED pool be very careful of the level of Chlorine being produced. If you use a salt chlorinated spa be very careful of the level of Chlorine as the Chlorinator is usually sized for the pool and therefore should be switched off when heating the spa. Leaving the chlorinator on can raise the chlorine level very rapidly in a small volume of water.

These comments are intended as a guide only and are not definitive answers or recommendations on pool water chemistry. Astral Pool's intention is to provide a little understanding of the potential problems of water chemistry and the dangers of corrosion to heaters (and other pool equipment and fittings).

 YOUR WATER SHOULD BE ADJUSTED & BALANCED PRIOR TO ANY CORRODED PARTS BEING REPLACED.

DIGITAL THERMOSTAT OPERATION

DESCRIPTION

The sophisticated digital thermostat provides temperature read out, set point temperature, operating status of the heater and any fault conditions.

TEMPERATURE DISPLAY

The temperature display indicates water temperature in the inlet of the heater. Therefore the pump must be operating for an accurate pool or spa water temperature to be displayed.

Comfortable pool temperature is between 26°C and 30°C. Normal spa temperature is between 36°C and 38°C. To select your desired temperature press the up or down button repeatedly until the desired temperature is reached.



To prevent rapid cycling of the heater, the thermostat has an inbuilt time delay which prevents the heater from turning on for two minutes after the set point has been reached. If the time delay is activated, the symbol "L" will be displayed on the LCD screen on the front of the heater. This is part of normal operation.

Should a fault condition occur, the heater will lock out and prevent further heating. A lock out condition is indicated by the symbols F0 to F9. To reset a lock out condition, turn the power off for five seconds.

When the water temperature is heated to within 1 degree of the thermostat set point, the HiNRG burner will turn down so that the set point is not exceeded. In addition, the set point is maintained very accurately, so the when using your spa pool, you will notice very little variation in water temperature.

DISPLAY SYMBOL INDICATION

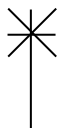
Under fault conditions the thermostat will display a set of alpha numeric symbols to indicate the status of the heater. The meaning of each symbol and action to be taken are listed as follows:

SYMBOL	MEANING	ACTION
Temp Display	Unit has power.	No action.
F0	Heater locked off, thermistor wire disconnected or water at 0°C (freeze conditions).	If water temperature reads greater than 0°C, phone for service.
F1	Thermostat reads greater than 45°C.	Allow water to cool below 40°C, turn heater off then on again.
F2	Mechanical Hi Limit greater than 43°C. or 52°C	Allow water to cool below 30°C, turn heater off then on again.
F3	Thermistor fault	Phone for Service
L	Heater locked out on time delay for 2 minutes.	No action. Heater will Automatically reset after time delay.
	Pump operating & sufficient water pressure to operate heater	No action.
	Thermostat calling for heat. Electronic Flame Supervision operating.	No action.
	Burner Operating	No Action

MAINTENANCE

It is recommended that you check the following at least every six months and at the beginning of every swimming season.

1. Examine the flue outlet and panel louvers for blockages. Make sure there are no obstructions to the flow of air to or from the appliance.
2. Keep the heater area clear and free of combustibles and flammable liquids. Chlorine should not be stored in the vicinity of the heater. Chlorine and acid vapours, when drawn through a heater, can rapidly cause corrosion of the heat exchanger.
3. Keep the heater area free from garden refuse and debris. This will help prevent insects nesting in the unit and ensure extended life and reliability of your heater.
4. Have your heater professionally inspected at least every 2 years or when used daily for 6 months each year, have it inspected one a year.

WINTER OPERATION

If the pool won't be used for a month or more, turn the heater off at the main gas isolation valve. For areas where there is no danger of freezing, water should circulate through your heater all year long even though you are not heating your pool.

Where freezing is possible, it is necessary to drain the water from the heater. This may be done by loosening the inlet or outlet barrel union. If the heater is below water level, isolate it from the pool first by closing shut off valves before and after the heater.



CAUTION: If the heater has been drained for freezing conditions, do not turn on until the system is circulating water

INSTALLATION



THIS APPLIANCE MUST BE INSTALLED BY AN AUTHORISED PERSON. Refer to heater data plate for specifications of gas type, gas consumption, burner pressure and water pressure.

This appliance must be installed in accordance with local regulations and Australian Standard Installation Code AS/NZ 5601. The installer must test the operation of the appliance before leaving.

For a heater in which no provision is made for a vent permanently open between the water circuit and atmosphere a pressure relief valve must be fitted in accordance with clause 2.8.7 of the Australian Standard for Gas Pool Heaters AS 4560-2004.

FLOW RATES

The HiNRG Pool Heater requires a minimum of 120 litres per minute (7.2 m³/hr) and a maximum flow rate of 500 litres per minute (30 m³/hr). It is recommended that an external bypass valve capable of bypassing some water be installed when flow rates exceed 375 litres per minute (22.5 m³/hr).

WATER CONNECTIONS

The heater should always be installed after the pump and filter. The water connections are located on the right hand side of the heater. The inlet and outlet are clearly marked. Water connections require 50 mm high pressure PVC glue-in plumbing. It is recommended that Class 12 (PN12) pipe be used to connect to the heater.

All automatic sanitising devices must be installed after the heater and in such a way that the sanitiser cannot enter the heater without first mixing with the water in the pool or spa. Sanitisers that are connected prior to the heater will void heater warranty.

A non-return valve is not required to be fitted between the filter and the heater.

PLUMBING DIAGRAM

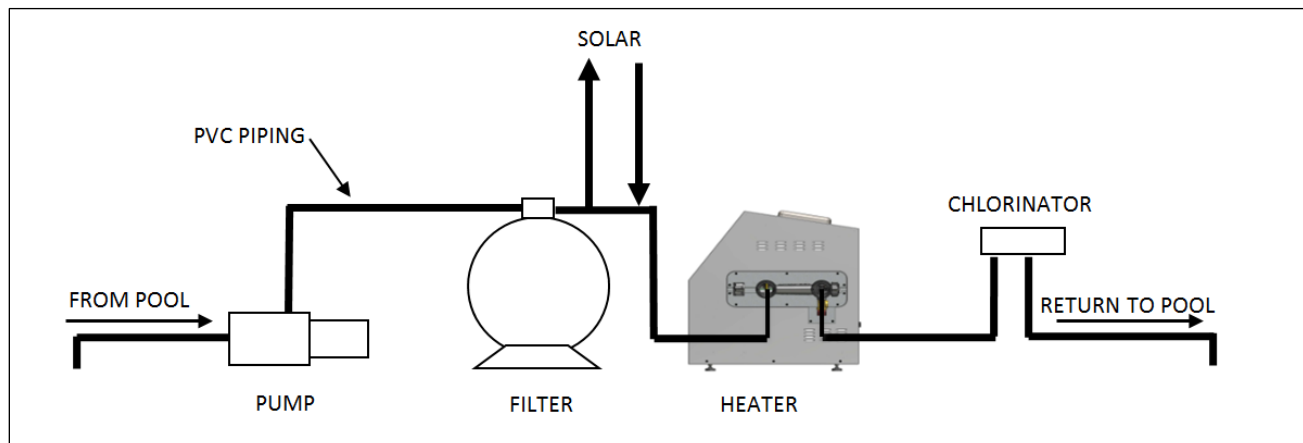

1. Plumbing in high pressure 50mm PVC pipe.
2. Connections to heater in Class 12 or higher.
3. All automatic Chlorinators or Sanitisers to MUST be installed after the heater.

HEATER DIMENSIONS

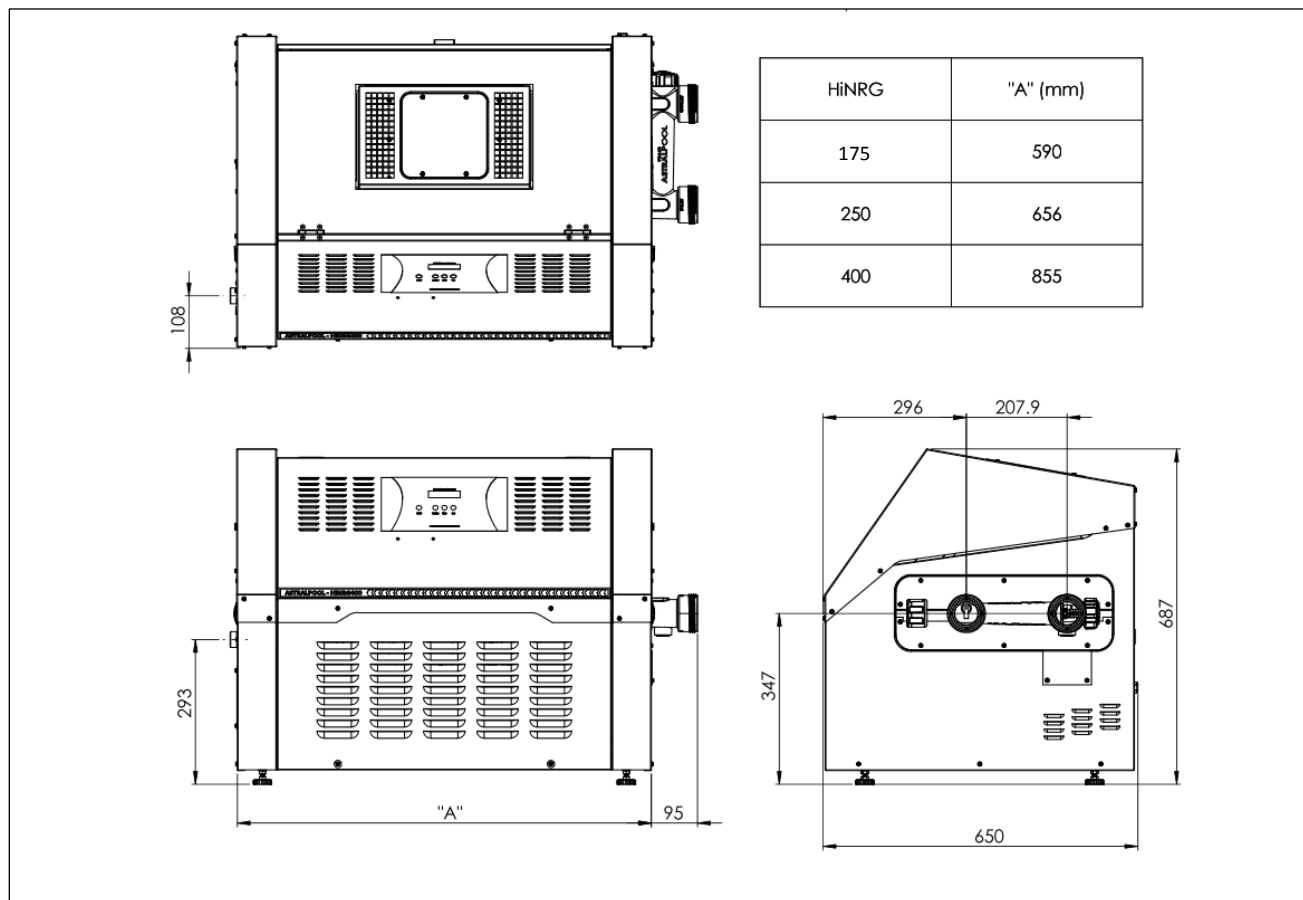

INDOOR FLUE INSTALLATION

For indoor installations a 125 mm flue and termination cowl must be fitted to the heater. The heater may be installed with a maximum of 16 metres of flue including 3 bends or of 8 metres of flue with a total of 5 bends.

The flue and termination cowl must be ordered from AstralPool.



Part # 78256 8 metre spiral flue with termination cowl

Part # 78259 4 metre x 125mm flue extension (maximum of two additional to make a total length of 16 metres)

Heater must be installed to AS/NZ 5601. Access and suitable working areas must be available to the heater.

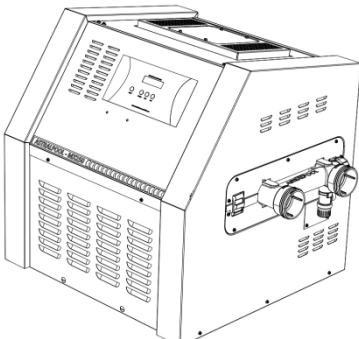
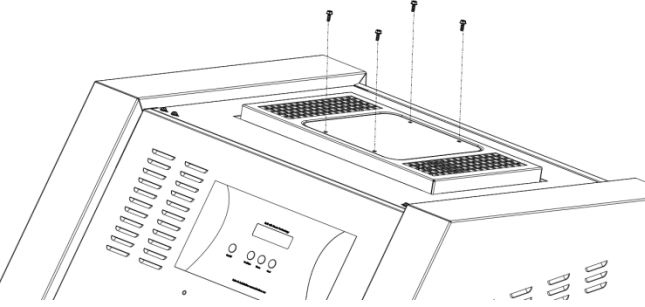
Flue pipe is supplied with a galvanised sleeved end for the external application and an non sleeved aluminium end for fitment to appliance. The flue pipe can be cut shorter with a knife/saw.

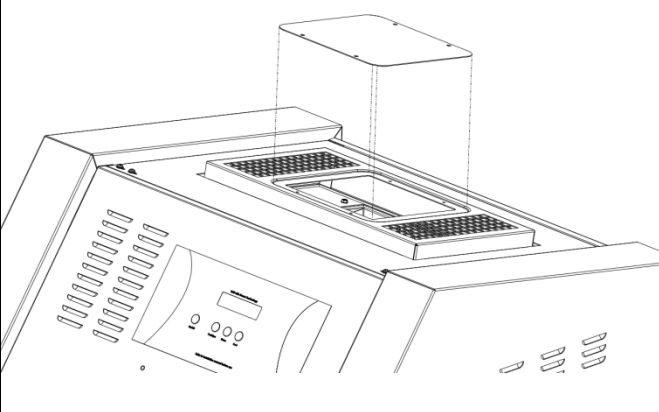
1	HINRG POOL HEATER – OUTDOOR MODEL.	
2	USING A PHILLIPS HEAD SCREW DRIVER UNSCREW 4 X SCREWS FROM FLUE COVER PLATE.	

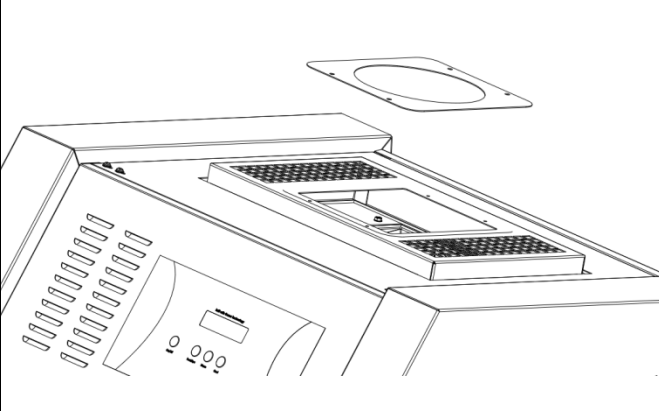
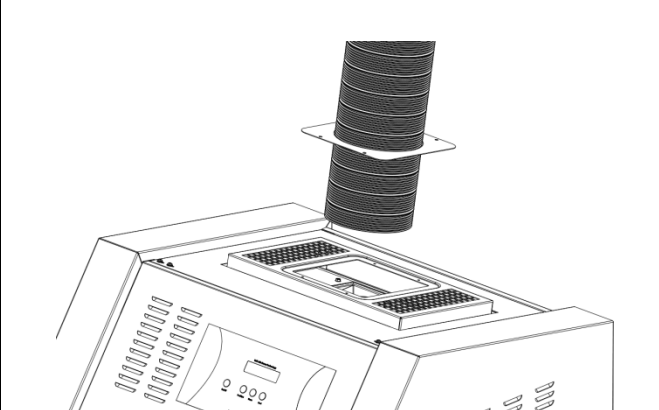
3	REMOVE FLUE COVER OUTDOOR INSERT.	 A technical line drawing of a boiler unit. A rectangular cover is shown being lifted away from the top of the boiler, revealing the flue pipe opening underneath. The boiler has various vents and a control panel on the front.
4	<p>PRE BEND THE FLUE WHERE REQUIRED. BENDS ARE MADE BY CURVING THE FLUE PIPE AROUND A GENTLE RADIUS SUCH AS A PIPE OR KNEE. DO NOT OVER BEND AND KINK FLUE PIPE. KEEP BENDS TO A MINIMUM AND USE AS LARGE AS RADIUS AS POSSIBLE. MINIMUM INTERNAL RADIUS IS 250MM.</p> <p>BENDS CAN BE STRAIGHTENED IF REQUIRED.</p>	 A photograph showing a person wearing a high-visibility yellow vest and dark trousers. They are holding a long, flexible, corrugated metal flue pipe and bending it around a large, curved metal pipe or structure in a workshop setting.
5	TAKE THE FLUE COVER INDOOR INSERT.	 A technical line drawing of the boiler unit. A circular cover is shown being lifted from the top of the boiler, revealing the flue pipe opening. The boiler has various vents and a control panel on the front.
6	TAKE THE FLUE AND PUT IT THROUGH THE INDOOR INSERT.	 A technical line drawing of the boiler unit. The flue pipe is shown being inserted into the circular indoor flue cover. The cover is positioned over the top of the boiler, and the pipe passes through its center.

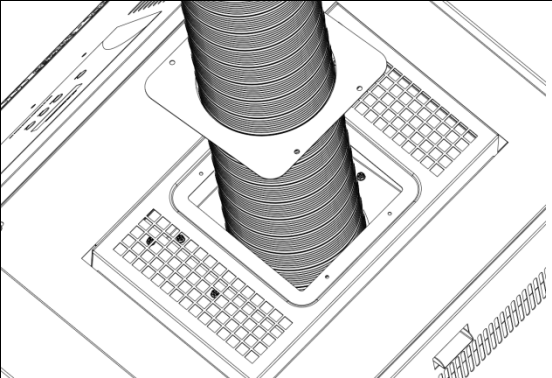
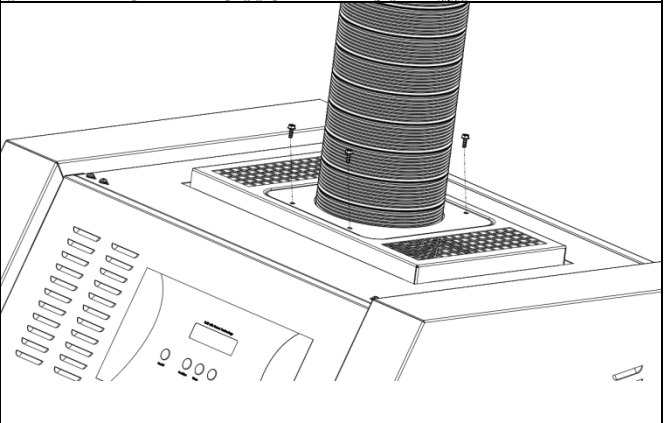
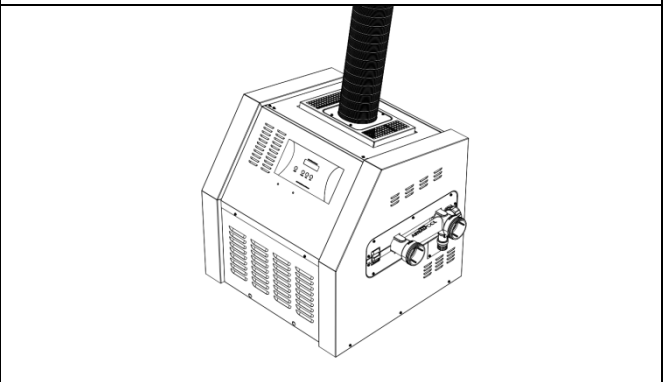
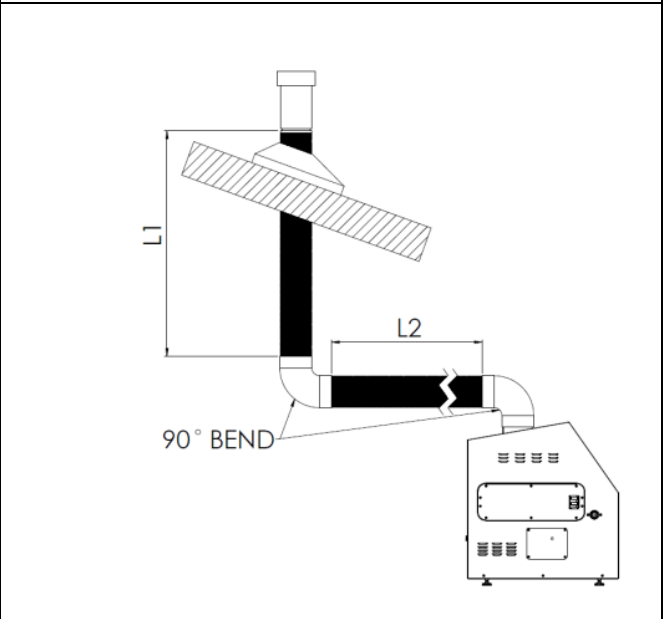
7	<p>FIT FLUE PIPE TO APPLIANCE (NON-SLEEVED END OF FLUE). FIT BY SLIDING IT OVER THE FLUE CONNECTION SPIGOT AS FAR AS POSSIBLE.</p>	
8	<p>SLIDE INDOOR INSERT PANEL DOWN THE FLUE AND SCREW INTO POSITION WITH 4 X SCREWS.</p>	
9	<p>HINRG POOL HEATER – INDOOR MODEL.</p>	
10	<p>FORM EXTRA BENDS WHERE REQUIRED. CARE SHOULD BE TAKEN WHEN FORMING BENDS TO NOT CREATE A LOW POINT WHERE CONDENSATION MAY COLLECT. CONDENSATION SHOULD BE ABLE TO DRAIN TO THE HEATER OR OUT THE FLUE OUTLET.</p> <p>THE FLUE SHOULD BE BRACKETED AT INTERVALS OF 1 M USING STANDARD 125 MM STANDOFF BRACKETS AVAILABLE AT MOST PLUMBING SUPPLIERS.</p>	

ROOFTOP TERMINATIONS

All flue exiting the roof must be shielded with the gal cover. Extra lengths of gal can be supplied. Decktite fittings / flashings must be attached to the galvanised flue cover. Brace flue in high wind applications.

Locate flue cowl onto reduced end of the gal outer covering / flue pipe. Attach with rivets / screws to hold into place.

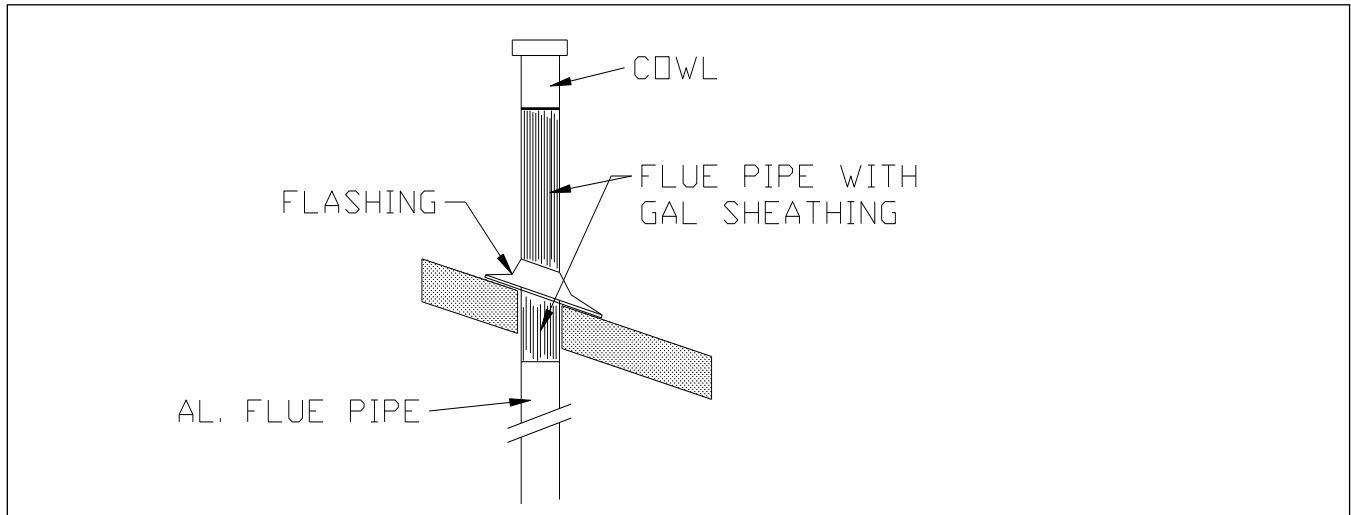

WALL TERMINATIONS

Ensure location is suitable as flue gases exit all around cowl and may blow back onto walls, eaves, features causing discolouration or mould and moisture issues. Condensation will occur around the flue exit area and condensation may drip from the flue outlet.

All flues exiting the wall must be shielded with the gal cover. Extra lengths of gal can be supplied. Decktite fittings / flashings / wall exiting covers must be attached to the galvanised flue cover.

For long extensions of flue exiting the wall bracing may be required in high wind applications.

Locate flue cowl onto reduced end of the gal outer covering / flue pipe. Attach with rivets / screws to hold into place.

Ensure a drain hole in the cowl is facing down.

The flue pipe must slope slightly towards the cowl for the last horizontal run (approx 2 deg) to allow condensation to drain.

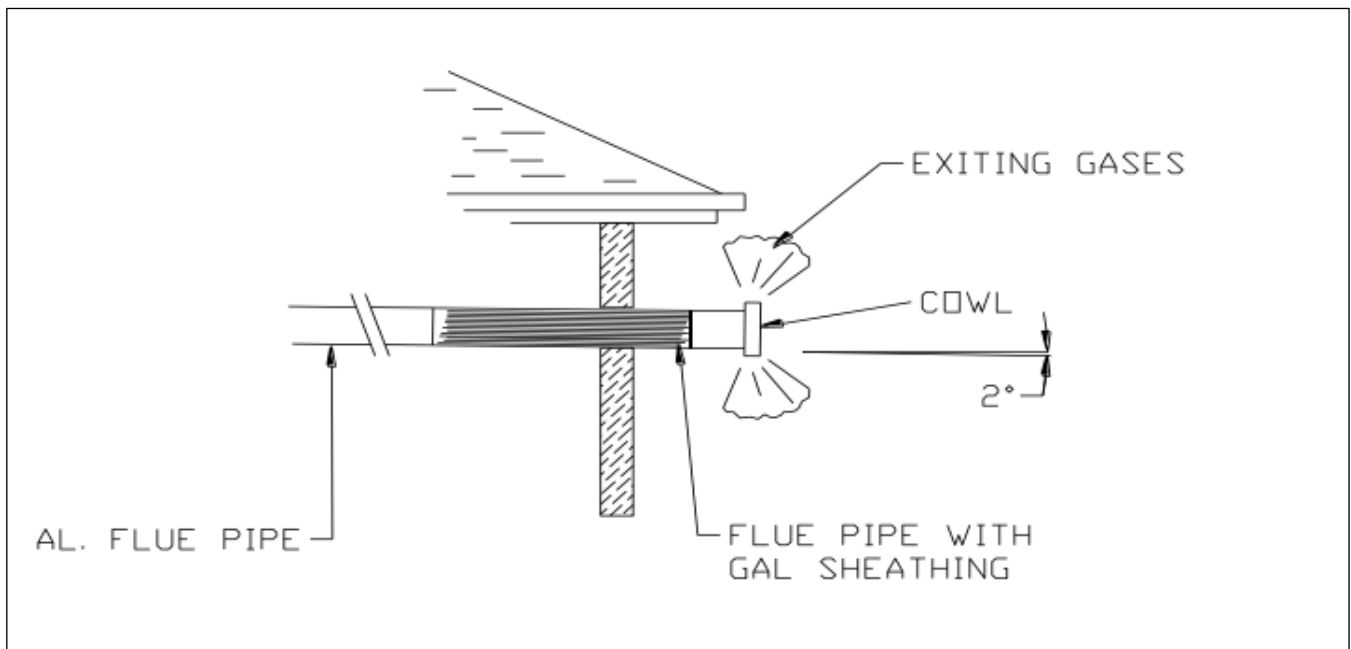

CLEARANCES

Installation clearances must comply with AS/NZ 5601. The heater is approved for installation at reduced clearances as below.

			SURFACE TYPE	
			COMBUSTIBLE	NON COMBUSTIBLE
CLEARANCES (mm)	OUTDOOR	FRONT	300	300
		BOTH SIDES	300	300
		REAR	300	100
		ABOVE	1000	1000
	INDOOR	FRONT	300	300
		BOTH SIDES	300	50
		REAR	300	100
		ABOVE	500	500

N.B. HEATERS MUST BE INSTALLED ON A FIREPROOF BASE

VENTILATION

When installing the heater indoors, it is imperative that an adequate supply of fresh air is provided for combustion. Failure to provide adequate ventilation voids all warranties and may be a danger to persons or property.

Two permanent openings shall be provided directly to outside. The openings shall be located to ensure the distance between the top of the upper opening and the ceiling of the room or enclosure, and the distance between the bottom of the lower opening and the floor of the room or enclosure does not exceed 5% of the height of the room or enclosure.

The minimum vertical dimension of any free ventilation opening shall be 6 mm.

The minimum free ventilation area provided directly outside by each opening shall be:

MODEL	AREA
HiNRG 175	60,000 mm ²
HiNRG 250	75,000 mm ²
HiNRG 400	120,000 mm ²

If ventilation provided is obtained from an adjacent room then these areas will increase.

The following diagram is provided as a guide only. All fluing and installation work must be carried out by an authorized person. Fluing must conform to local regulations and to A.G.A. installation code AS/NZ 5601. Care must be taken to provide the correct ventilation and correct fluing materials in close proximity to combustible surfaces.

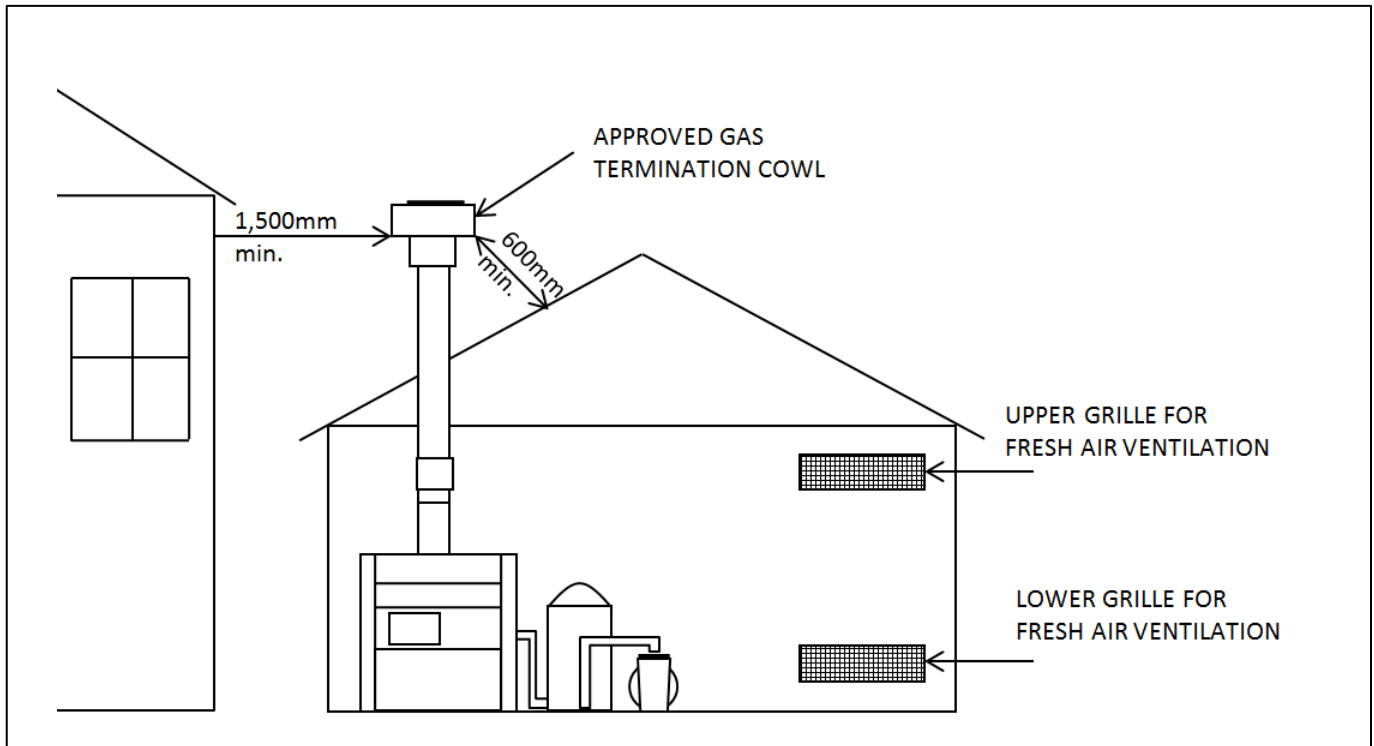

⚠ Do not install spa blowers in the same room as a gas heater. This is potentially dangerous to spa users.

⚠ Do not store chemicals or fuel in the same room as the gas heater. This may cause fire or explosion. When installing in a garage the HiNRG Series Heater must be installed 450 mm above floor level.

ELECTRICAL CONNECTION

The heater is supplied with a standard 10 amp 3 pin plug for connection to a 240V 10 amp GPO. All pool or spa equipment connected to mains power should be protected by an RCD circuit breaker.

GAS CONNECTION

175/250/400 MODELS:

The gas connection is on the right side of the heater. A 20mm FI. connection is provided for gas line connection. An approved manual shut off valve must be installed in the gas fitting line before the heater.

The gas fitting line should be installed by an authorised person and comply with local regulations and Australian Standard code AS/NZ 5601. The gas line from the meter will usually be of a larger size than the gas inlet connection.

The heater gas valve has a built in pressure regulator and 2 x 1/8" pressure test point. On starting the heater, a manometer must be used and the supply inlet pressure checked while the heater is running against the heater data plate. Incorrect inlet pressures may void warranty and may result in service charges, should service be required. Gas valves are pre-set and should only be adjusted by trained Astral Pool technicians or qualified gas fitters.

WATER PRESSURE SWITCH ADJUSTMENT

The HiNRG Pool Heater incorporates a water pressure switch which allows the burner to operate only when the circulating pump is operating. The pressure switch is designed to operate with the heater installed up to 3 metres above or below the surface level of the pool or spa.

It is imperative that the following be undertaken by the person who is commissioning (first starting) your pool or spa heater. On initial start-up of the heater it may be necessary to adjust the water pressure activation switch.

This switch is located behind the front door in the front right corner. The pressure switch is a safety device, designed to allow operation of the heater only when the circulating pump is on and there is sufficient water flow through the heater. It must shut the heater down immediately after the pump is switched off.

TO CHECK THE OPERATION OF THE SWITCH:

1. Check water pump hair and lint basket is clean and free of debris and backwash sand filter or clean cartridge filter. Pressure switch should only be checked and adjusted with clean skimmer, pump basket and filter.
2. Connect the heater to mains power supply and turn power on. The thermostat should not yet display "θ".
3. Turn on pump. The thermostat should now display "θ".
4. Turn pump off. The thermostat should no longer display "θ".
5. If display does not respond in this way, adjust the pressure switch as detailed below. If display responds correctly, perform a final check with the heater operating – see the section below titled "Starting the heater".

TO ADJUST PRESSURE SWITCH:

1. Connect the heater to mains power supply and turn power on. The thermostat should not yet display "θ".
2. Turn on pump.
3. View the display of the heater to confirm the "θ" has appeared on the LCD display on front of heater.
4. If no symbol is present, slide the toggle up to allow adjustment, then rotate knurled wheel anti clockwise (as viewed from above) until "θ" is displayed.
5. Switch pump off.
6. View LCD display to confirm the "θ" has disappeared.
7. If "θ" symbol is present when pump is OFF or "θ" does not disappear within 1 (one) second of pump turning off, the pressure switch must be adjusted.
8. With Pump turned OFF, turn knurled wheel clockwise to increase the pressure required to activate the switch.
9. Repeat steps 2 to 8 until symbol appears and disappears when pump turns on and off.
10. When the pressure switch is correctly set, slide the toggle down to lock the knurled wheel in position.
11. If pressure switch cannot be made to activate heater when pump is turned on and off, a flow switch may need to be purchased and fitted. Contact your local Astral Pool office for details.

⚠ WARNING: If the pressure switch cannot be adjusted correctly, DO NOT OPERATE THE HEATER, contact Astral Pool or an Authorised Service Agent for advice.

1. Perform a final check with the heater operating. See the section below titled "Starting the heater".

It is imperative that the heater is installed so that it does not operate when the circulating pump stops. Recommended methods to achieve this are:

- a. Correct adjustment of internal pressure switch. Ensure heater does not turn on two or three minutes after circulating pump is turned off.
- b. Installation of an external flow switch may be preferred under certain installations where internal pressure switch does not turn heater off when circulator stops.

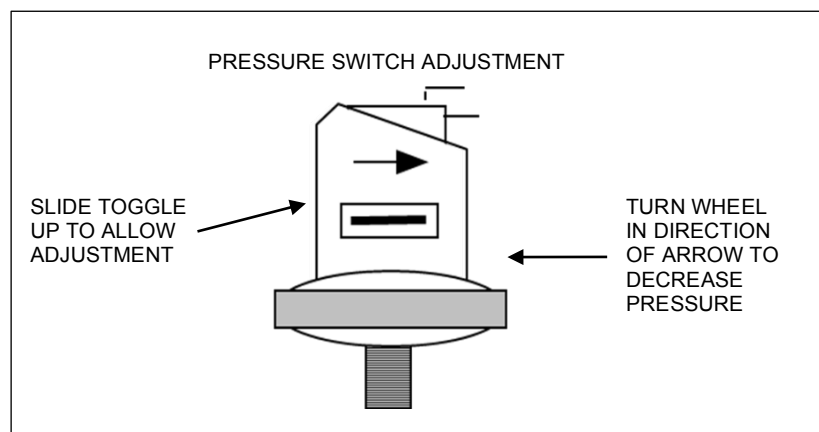

TESTING GAS PRESSURE

1. **Note – gas pressure must be measured when unit is operating.**
2. Set thermostat to “OFF”.
3. Remove screws from front thermostat panel and open.
4. Loosen screw from 1/8” brass test point located on outlet side of gas valve (between the valve and the burner)
5. Connect manometer tube to test point
6. Set thermostat to “ON” and wait for burner to ignite
7. Once burner has ignited, the manometer must indicate the nominal inlet pressure listed below.
8. Remove the regulator cap on the gas valve and adjust the regulator pressure to achieve the specified burner operating pressure
9. If the regulator cannot be adjusted to achieve the specified burner pressure, it is likely the gas line to the appliance is insufficient
10. Remove manometer
11. Tighten test point screw
12. Replace regulator cap
13. Refit covers.

 Important to check that Test point screw has been refitted and tightened.

		HiNRG HEATER MODEL					
		175		250		400	
		NATURAL	PROPANE	NATURAL	PROPANE	NATURAL	PROPANE
GAS INLET RATES (MJ/h)		175	175	250	250	400	400
GAS TEST POINT PRESSURE (kPa)	INLET STATIC	1.13 MIN. 5.00 MAX.	2.75 MIN. 5.00 MAX.	1.13 MIN. 5.00 MAX.	2.75 MIN. 5.00 MAX.	1.13 MIN. 5.00 MAX.	2.75 MIN. 5.00 MAX.
	INLET OPERATING (HIGH FIRE)	>1.13	>2.75	>1.13	>2.75	>1.13	>2.75
	BURNER OPERATING (HIGH FIRE)	0.52	2.00	0.54	2.00	0.54	2.00
CO LEVELS (ppm)		10 to 30		10 to 30		10 to 30	

PERFORMANCE DETAILS

TO CHECK BURNER PERFORMANCE

1. Start pool pump supplying water to HiNRG Gas Heater and ensure heater is turned off
2. Set up manometer to outlet side of gas valve
3. Turn HiNRG Heater on at the on/off switch
4. Increase temperature set point above the actual water temperature
5. Allow the heater to start
6. Ensure heater is running at full fan rate.
7. Inspect flame from the flame inspection port inside the heater and ensure flames are blue
8. Check gas pressure on Manometer
9. Remove regulator cap on gas valve and adjust gas rate screw to achieve nominated burner pressure
10. Inspect flame again ensuring flame is blue in colour
11. Turn heater off and ensure the flame cuts out and the pressure switch symbol on the thermostat screen disappears
12. Turn heater on again, and ensure the thermostat displays "L" for lockout. Wait 2 minutes and the heater should then reignite.
13. Lower front door and secure shut.

TROUBLESHOOTING

HEATER WILL NOT LIGHT	
Possible cause	Remedy
No display	Check if power to heater is turned on
Pump not running	Start pump
Pump air locked	Check for leaks
Filter dirty	Clean filter
Pump strainer basket clogged	Clean strainer
Thermostat turned off	Turn on
Set temperature lower than water temperature	Increase set temperature
Water too hot-fault condition displayed	Refer to fault indication table
Gas turned off	Turn gas cock on
Heater in a Fault condition	Refer to fault indication table
HEATER SHORT CYCLING (RAPID ON AND OFF OPERATION)	
Possible cause	Remedy
Insufficient water flow	Clean filter and pump strainer
HEATER MAKING KNOCKING NOISES	
Possible cause	Remedy
Low water flow	Check pump condition
Heater operating after pump has shut off	Shut off gas supply and call for service
Heat exchanger scaled	Shut off gas supply and call for service

IGNITION MODULE LED FLASH CODE

THE FOLLOWING CODES MAY OCCUR DURING STARTUP		
LONG FLASHES	SHORT FLASHES	DESCRIPTION
0	2	NORMAL OPERATION – START UP DELAY
1	0	NORMAL OPERATION
1	1	FLAME FAILURE DETECTED
1	2	WAITING FOR MAIN PRESSURE SWITCH
1	3	WAITING FOR SECOND PRESSURE SWITCH
1	4	WAITING FOR FLAME SENSE TO GO OFF
1	5	PURGE OPERATION IN PROGRESS (PRE PURGE OR POST PURGE)
1	8	WAITING FOR FAN TACHO FEEDBACK SIGNAL TO BE WITHIN ACCEPTABLE WINDOW (MODULE OPTION)
THE FOLLOWING CODES ARE INVOKED AS A RESULT OF A LOCKOUT CONDITION		
LONG FLASHES	SHORT FLASHES	DESCRIPTION
2	1	MAXIMUM RETRIES EXCEEDED
2	2	LOCK OUT DUE TO FLAME FAILURE
2	3 OR 4 OR 5	HARDWARE FAILURE ON MODULE OUTPUT(S). POSSIBLE HARDWARE FAILURE ON MODULE
2	6	HARDWARE FAILURE ON FLAME SENSING CIRCUIT
2	7	HARDWARE FAILURE IN MODULE
2	8	COMBUSTION FAN TIMEOUT (WHERE FITTED)
2	9	VENT SWITCH LOCKOUT (WHERE FITTED)
THE FOLLOWING CODES ARE INVOKED AS A RESULT OF A LOCKOUT CONDITION/HARDWARE FAULT		
LONG FLASHES	SHORT FLASHES	DESCRIPTION
3	1	LOCKOUT DUE TO MAIN PRESSURE SWITCH OPENING (WHERE FITTED)
3	2	LOCKOUT DUE TO SECOND PRESSURE SWITCH OPENING (WHERE FITTED)
3	3	LOCKOUT DUE TO FAN TACHO. FEEDBACK SIGNAL FAILING (WHERE FITTED)
3	4	LOCKOUT DUE TO INTERNAL FAULT (SOFTWARE ERROR)
3	5	LOCKOUT DUE TO INTERNAL FAULT (EEPROM ERROR)
3	6	LOCKOUT DUE TO INTERNAL FAULT (MICROCONTROLLER COMMUNICATIONS ERROR)

If the heater cannot be made to perform correctly, please contact the Astral Pool office closest to you.

GAS PIPE SIZING TABLES

1.13 kPa gas meter pressure					
Some areas of VICTORIA					
Maximum run of copper pipe with average number of fittings					
Model	20 mm	25 mm	32 mm	40 mm	50 mm
HINRG 175	2 m	8 m	30 m	75 m	320 m
HINRG 250	-	8 m	14 m	35 m	140 m
HINRG 400	-	3 m	8 m	20 m	90 m
1.25 kPa gas meter pressure					
S.A., W.A., some areas N.S.W.					
Maximum run of copper pipe with average number of fittings					
Model	20 mm	25 mm	32 mm	40 mm	50 mm
HINRG 175	6 m	25 m	90 m	240 m	320 m
HINRG 250	3 m	14 m	45 m	110 m	320 m
HINRG 400	2 m	8 m	25 m	70 m	300 m
2.75 kPa gas meter pressure					
N.S.W. some areas, Victoria some areas, Qld some areas					
Maximum run of copper pipe with average number of fittings					
Model	15 mm	20 mm	25 mm	32 mm	
HINRG 175	4 m	40 m	160 m	320+ m	
HINRG 250	2 m	20 m	85 m	280 m	
HINRG 400	-	12 m	50 m	160 m	

Gas Pipe Sizing Tables are indicative only. All pipe sizing should be calculated by an authorised person.

HINRG WIRING DIAGRAM

ALL MODELS

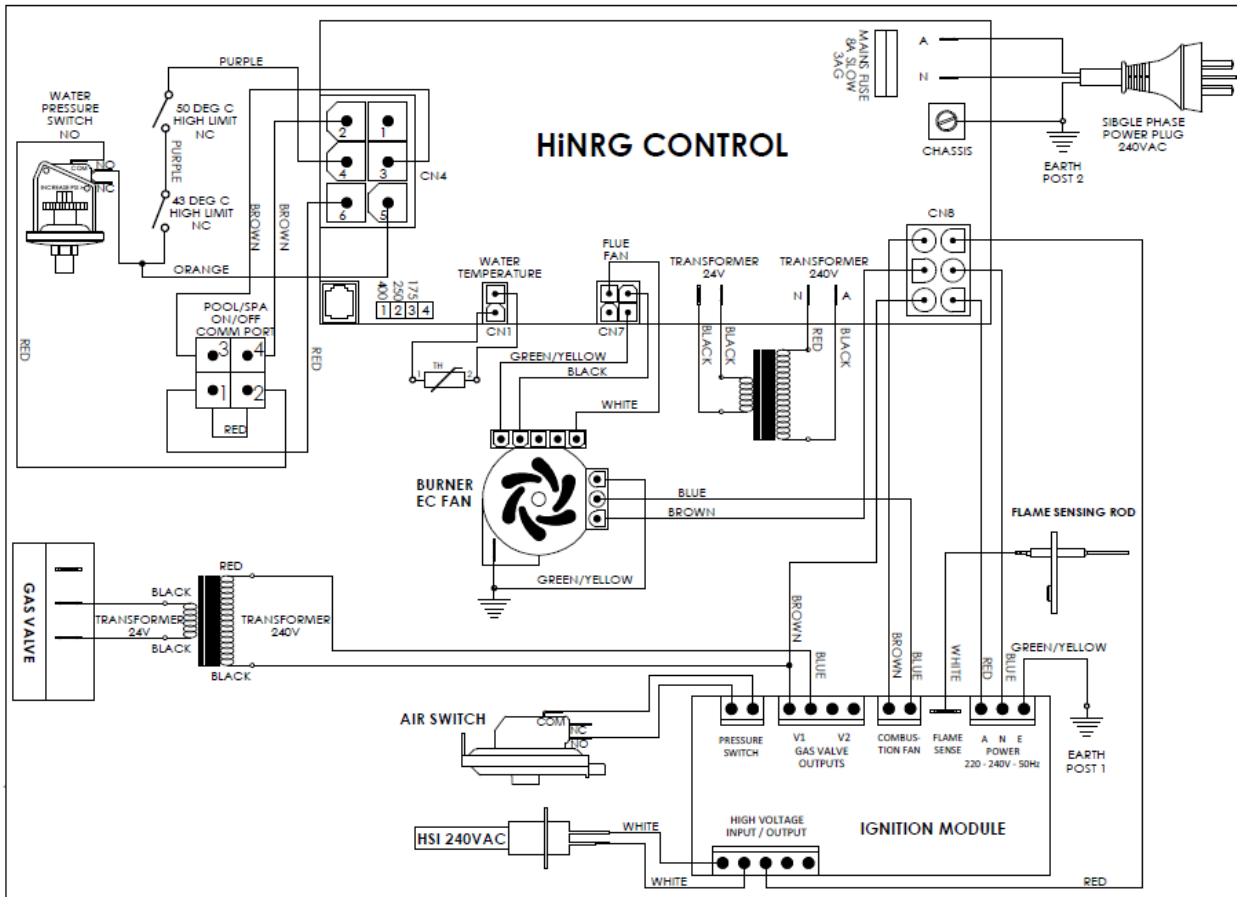

MAINTENANCE OF YOUR POOL HEATER

Maintenance Schedule: Your new product incorporates moving parts and withstands high velocity water with chemicals in it. Some of these parts will wear in the normal course of use and require regular checks and maintenance.

Performing these checks and maintenance will identify parts that have worn and require repair/replacement before further serious damage is sustained. A small amount of regular care and attention to your pool equipment will help ensure long life and trouble free performance.

Timing	Maintenance Check	Service action (if required)
Monthly	Operate heater for 15 min to clear residues and ensure correct operation	Start circulation pump and turn heater on, leaving to run for a few minutes. This will clear flue passages and keep components working properly
Three Monthly	Check inlet/outlet O-rings for leaks	Isolate Pump, turn power off, clean and grease O rings or replace if necessary
Three Monthly	Check surroundings for leaves, debris and flooding	Remove debris from around the base of the heater and rectify if any flooding. Clear vegetation from around the flue
Annually	Check gas pressures Check Burner, pilots and ignition systems	Call Service technician to perform annual gas checks and routine maintenance Must be completed by an authorised person

Important note: Regular maintenance is important to ensure long life and trouble free performance of your pool equipment. If unable to perform the maintenance yourself, contact your local AstralPool office who will arrange a trained service technician to perform the maintenance for you.

Filter

WARRANTY TERMS AND CONDITIONS

Astral Pool Australia Pty Ltd (ABN 97 007 284 504) ("Astral Pool") provides the following warranty in relation to its HiNRG series gas pool & spa heaters.

Our goods come with guarantees that cannot be excluded under the Australian Consumer Law. You are entitled to a replacement or refund for a major failure and for compensation for any other reasonably foreseeable loss or damage. You are also entitled to have the goods repaired or replaced if the goods fail to be of acceptable quality and the failure does not amount to a major failure.

The benefits of this warranty are in addition to any rights and remedies imposed by Australian state and federal legislation that cannot be excluded. Nothing in this warranty is to be interpreted as excluding, restricting or modifying any state or federal legislation applicable to the supply of goods and services which cannot be excluded, restricted or modified.

WARRANTY

Astral Pool warrants that, subject to the exclusions and limitations below, the product will be free from defects in materials and workmanship during the warranty period. The warranty periods are set out below and commence 30 days after the date of purchase (to allow for installation) subject to the exclusions listed below. The warranty period may vary for different parts of the Product.

Parts	Warranty Period
Cabinet, refractory insulation and combustion chamber	5 years
Components such as gas valve, thermostat, pilot, wiring, burner, gaskets	3 years
Heat exchanger, inlet and return water headers	3 years
Hot surface ignitor	10,000 hours or 7,000 ignition attempts as counted on the HiNRG control module

If a defect appears in the product before the end of the warranty period and Astral Pool finds the product to be defective in materials or workmanship, Astral Pool will, in its sole discretion, either:

- (a) replace or repair the product or the defective part of the product free of charge; or
- (b) cause the product or the defective part of the product to be replaced or repaired by an authorised Astral Pool Service Agent free of charge.

Astral Pool reserves the right to replace defective parts of the product with parts and components of similar quality, grade and composition where an identical part or component is not available.

Goods presented for repair may be replaced by refurbished goods of the same type rather than being repaired. Refurbished parts may be used to repair the goods.

WARRANTY CLAIMS

1. If a fault covered by warranty occurs, the customer must first contact Astral Pool at the contact address listed below, or an Authorised Astral Pool Service Agent.
2. Any warranty claim must be accompanied by:
 - (a) proof of purchase;
 - (b) full details of the alleged defect; and
 - (c) appropriate documentation (such as historical and maintenance records).
3. The customer must make the product available to Astral Pool or its authorised Astral Pool service agent for inspection and testing. Astral Pool or its authorised Astral Pool service agent will attend the premises where the product is installed for inspection and testing. If the product is installed:
 - (a) outside a capital city metropolitan area; and
 - (b) is not within a 20 km radius of an Authorised Astral Pool Service Agent;

then the customer may have to pay a travel fee.
4. If such inspection and testing finds no defect in the product, the customer must pay Astral Pool's usual costs of service work and testing. If such inspection and testing finds a defect that is not covered by this warranty, the customer must pay Astral Pool's usual costs of service work plus any parts and labour required to repair the Product, unless recoverable from Astral Pool on the failure of any statutory guarantee under the ACL.

Exclusions

The warranty will not apply where:

- (a) the customer is in breach of the Terms and Conditions of Sale;
- (b) the Product was used for a purpose other than one it was intended for;
- (c) the Product was repaired, modified or altered by any person other than Astral Pool;
- (d) the Product has not been installed, maintained and/or operated in complete compliance with the installation and operating instructions and any instructions by Astral Pool;
- (e) the Product has been subject to accident, negligence, alteration, abuse or misuse.

The warranty does not extend to:

- a) normal wear and tear;
- b) weather and other environmental conditions including but not limited to storm, flood, and/or heat wave damage; or
- c) service and maintenance items.

Examples of exclusions include but are not limited to:

- Incorrect/insufficient gas supply
- Incorrect/insufficient ventilation
- Incorrect water balance

LIMITATIONS

Astral Pool makes no express warranties or representations other than set out in this warranty.

The repair or replacement of the Product or part of the Product is the absolute limit of Astral Pool's liability under this express warranty.