



Astral Pool Inverter Heat Pump



Contents

1. Preface	1
2. Specifications	2
2.1 Performance Data of Swimming Pool Heat Pump Unit	4
2.2 Dimensions for Swimming Pool Heat Pump Unit	5
3. Installation and Connection	6
3.1 Installation of System	6
3.2 Swimming Pool Heat Pumps Location	6
3.3 How Close to Your Pool?	6
3.4 Swimming Pool Heat Pumps Plumbing	7
3.5 Swimming Pool Heat Pumps Electrical Wiring	9
3.6 Initial Start-up of the Unit	9
4. Usage and Operation	13
4.1 Function of the controller	13
4.2 Usage of the controller	15
4.3 Parameter setting	19
5. Maintenance and Inspection	20
5.1 Malfunction table	20
6. Appendix	21
6.1 Connection of PCB illustration	22
6.2 Caution & Warning	23
6.3 Cable specification	24

3.INSTALLATION AND CONNECTION

- In order to provide our customers with quality, reliability and versatility, this product has been made to strict production standards. This manual includes all the necessary information about installation, debugging, discharging and maintenance. Please read this manual carefully before you open or maintain the unit. The manufacture of this product will not be held responsible if someone is injured or the unit is damaged as a result of improper installation, debugging, or unnecessary maintenance. It is vital that the instructions within this manual are adhered to at all times. The unit must be installed by qualified personnel.
- The unit can only be repaired by qualified installer center personnel or an authorized dealer.
- Maintenance and operation must be carried out according to the recommended time and frequency, as stated in this manual.
- Use genuine standard spare parts only.
Failure to comply with these recommendations will invalidate the warranty.
- Swimming Pool Heat Pump Unit heats the swimming pool water and keeps the temperature constant. For split type unit, the indoor unit can be Discretely hidden or semi-hidden to suit a luxury house.

Our heat pump has following characteristics:

1 Durable

The heat exchanger is made of PVC & Titanium tube which can withstand prolonged exposure to swimming pool water.

2 Installation flexibility

The unit can be installed outdoors or indoors.

3 Quiet operation

The unit comprises an efficient rotary/ scroll compressor and a low-noise fan motor, which guarantees its quiet operation.

4 Advanced controlling

The unit includes micro-computer controlling, allowing all operation parameters to be set. Operation status can be displayed on the LED wire controller. Remote controller can be chosen as future option.

INTRODUCTION

Congratulations on the purchase of an Astral Pool Heat Pump, Pool and Spa Heater. Proper installation and service of your new heating system and correct chemical maintenance of the water will ensure many years of service. It is equipped with features that take advantage of new technology developed exclusively by Astral Pool.

This unit can safely be connected to PVC pipe. In addition, the unit is equipped with an accurate electronic thermostat to ensure ease of use and accurate temperature control. The electronic display tells at a glance the operational status of the heater.

Your heat pump works by extracting heat from the surrounding air. The heat pump works most efficiently in warm weather. So, it is best to operate the heat pump during the warmest part of the day rather than overnight or early in the morning.

It is important to ensure an adequate supply of air and to avoid recirculation of the cooled air exiting the top of the unit. For this reason, the heat pump should not be installed in confined spaces and must have a minimum of 500 mm clearance above it and 700 mm clearance to the sides and 300 mm to the rear. A clearance of 2500mm is required to the front of the unit to allow access to the controls and service panel.

Although the unit is weatherproof, it is recommended some protection from the harsh effects of direct exposure to the elements be provided.

The heat pump **must** be installed outdoors on a level concrete pad.

In most circumstances where heating is required, the heat pump will need to run longer than the filtration. For the most effective heating it may be necessary to install a small pump to circulate water through the heat pump independent of the filtration system. Since the heat pump uses electricity so efficiently, it is a pity to waste electricity running an oversized pump. For this reason, the small added cost of a dedicated pump can be recouped and a great deal of energy saved over the life of the heater.

Note:

The appliance is not intended for use by young children or infirm person without supervision. Please ensure that young children are supervised to ensure that they do not play with the appliance.

NOTICE TO INSTALLERS

Heat Pump must be located outdoors with sufficient ventilation as explained on page 6.

This appliance must be installed by an authorized person.

This appliance must be installed in accordance with the installation instructions, the National Wiring Rules and any other relevant statutory authorities.

Refer to data plate for details of operating voltage and current.

A multi-pole isolating switch must be installed that operates in all live conductors so that it isolates the entire equipment from the supply.

SAFETY RULES

1. Spa or hot tub water temperature should never exceed 40°C.
2. Drinking of alcoholic beverages before or during spa or hot tub use can cause drowsiness which could lead to unconsciousness and subsequently result in drowning.
3. Pregnant women beware! Soaking in water above 38°C can cause foetal damage during the first three months of pregnancy.
4. Before entering the spa or hot tub, the user should check the water temperature with an accurate thermometer, spa or hot tub thermostats may be inaccurate by as much as 2°C.
5. Persons with a medical history of heart disease, circulatory problems, diabetes or blood pressure problems should obtain their physician's advice before using spas or hot tubs.
6. Persons taking medications which induce drowsiness, such as tranquillisers, antihistamines or anticoagulants, should not use spas or hot tubs. If in doubt seek medical advice.

Phase rotation must be checked on 3 phase units. Incorrect rotation will damage the compressor and void any warranties. Performance data of Swimming Pool Heat Pump Unit

CHEMICAL BALANCE

It is imperative that correct chemical balance be maintained in your pool and spa water, otherwise corrosion of your heater may occur. **Corrosion due to chemically imbalanced water or excessive sanitiser is detectable and will void warranty.** Your local pool shop specialist or spa retailer can advise correct chemical balance. Your water should be checked and maintained regularly by a pool water professional. As a guide the following parameters may be used.

pH	7.6 to 7.8
Total Alkalinity	80 to 120 ppm
Calcium Hardness	150 ppm

You should test your water chemical balance at least on a weekly basis.

Excessive sanitiser can damage your heater. Chlorine should not exceed 3 ppm and bromine should not exceed 5 ppm. Salt chlorinators, especially when used on spa pools or indoor or covered pools, can easily produce excessive chlorine levels which will damage the heater internals.

WINTER OPERATION

If the pool won't be used for a month or more, turn the heater off at the main isolating switch. For areas where there is no danger of freezing, water should circulate through your heater all year long even though you are not heating your pool.

Where freezing is possible, it is necessary to drain the water from the heater. This may be done by loosening the inlet or outlet barrel union. If the heater is below water level, isolate it from the pool first by closing shut off valves before and after the heater.

CAUTION: If the heater has been drained for freezing conditions, do not turn on until the system is circulating water.

2.SPECIFICATION

2.1 Performance data of Swimming Pool Heat Pump Unit

REFRIGERANT : R410A

UNIT		78542	78543
Nominal Heating Capacity(85Hz)	kW	9	12
	Btu/h	30600	40800
Range	kW	2.15~9	2.85~12
	Btu/h	7310~30600	9690~40800
*Nominal Heating Power Input(85Hz)	kW	1.6	2.12
*Range	kW	0.16~1.6	0.21~2.12
*Nominal Running Current Input(85Hz)	A	7.0	9.4
*Range	A	0.8~7.0	1.1~9.4
**Nominal Heating Capacity(85Hz)	kW	7.4	9.7
	Btu/h	25160	32980
**Range	kW	1.75~7.4	2.25~9.7
	Btu/h	5950~25160	7650~32980
**Nominal Heating Power Input(85Hz)	kW	1.6	2.08
**Range	kW	0.25~1.6	0.32~2.08
**Nominal Running Current Input(85Hz)	A	7.0	9.2
**Range	A	1.2~7.0	1.6~9.2
***Nominal Heating Capacity(85Hz)	kW	6.1	8
	Btu/h	20740	27200
***Range	kW	1.42~6.1	1.88~8
	Btu/h	4828~20740	6392~27200
***Nominal Heating Power Input(85Hz)	kW	1.5	1.95
***Range	kW	0.25~1.5	0.33~1.95
***Nominal Running Current Input(85Hz)	A	6.6	8.7
***Range	A	1.2~6.6	1.7~8.7
Power Supply		220-240 /50Hz	
Compressor Quantity		1	1
Compressor		rotary	rotary
Fan Quantity		1	1
Fan Power Input	W	100	100
Fan Rotate Speed	RPM	400-800	400-800
Fan Direction		horizontal	horizontal
Noise	dB(A)	40-50	42-52
Water Connection	mm	50	50
Water Flow Volume	m ³ /h	3.2	4.2
Water Pressure Drop(max)	kPa	4.0	4.5
Unit Net Dimensions(L/W/H)	mm	See the drawing of the units	
Unit Ship Dimensions(L/W/H)	mm	See package lable	
Net Weight	kg	see nameplate	
Shipping Weight	kg	see package label	

Rated Heating: Outdoor air temp: °C °C, Inlet water temp:26 °C/28 °C
 °COutdoor air temp: 15 °C °C, Inlet water temp:26 °C/28 °C
 Outdoor air temp: 10 °C °C, Inlet water temp:26 °C/28 °C

2.SPECIFICATION

2.1 Performance data of Swimming Pool Heat Pump Unit

REFRIGERANT : R410A

UNIT		78544	78545
Nominal Heating Capacity(85Hz)	kW	17	19.5
	Btu/h	57800	66300
Range	kW	3.77~17	4.6~19.5
	Btu/h	12818~57800	15640~66300
*Nominal Heating Power Input(85Hz)	kW	3.02	3.94
*Range	kW	0.3~3.02	0.37~3.94
*Nominal Running Current Input(85Hz)	A	13.3	17.2
*Range	A	1.5~13.3	1.8~17.2
**Nominal Heating Capacity(85Hz)	kW	12.4	15.4
	Btu/h	42160	52360
**Range	kW	2.92~12.4	3.84~15.4
	Btu/h	9928~42160	13056~52360
**Nominal Heating Power Input(85Hz)	kW	2.86	3.81
**Range	kW	0.44~2.86	0.6~3.81
**Nominal Running Current Input(85Hz)	A	12.6	16.7
**Range	A	2.2~12.6	2.8~16.7
***Nominal Heating Capacity(85Hz)	kW	10.7	14.4
	Btu/h	36380	48960
***Range	kW	2.5~10.7	3.38~14.4
	Btu/h	8500~36380	11492~48960
***Nominal Heating Power Input(85Hz)	kW	2.64	3.62
***Range	kW	0.45~2.64	0.62~3.62
***Nominal Running Current Input(85Hz)	A	11.6	15.8
***Range	A	2.3~11.6	3.0~15.8
Power Supply		220-240 /50Hz	
Compressor Quantity		1	1
Compressor		rotary	rotary
Fan Quantity		1	1
Fan Power Input	W	120	120
Fan Rotate Speed	RPM	500-750	500-900
Fan Direction		horizontal	horizontal
Noise	dB(A)	44-53	45-56
Water Connection	mm	50	50
Water Flow Volume	m ³ /h	5.3	6.6
Water Pressure Drop(max)	kPa	5	6
Unit Net Dimensions(L/W/H)	mm	See the drawing of the units	
Unit Ship Dimensions(L/W/H)	mm	See package label	
Net Weight	kg	see nameplate	
Shipping Weight	kg	see package label	

Rated Heating: Outdoor air temp: ℃ ℃, Inlet water temp:26 ℃/28
 ℃Outdoor air temp: 15 ℃ ℃, Inlet water temp:26 ℃/28 ℃
 Outdoor air temp: 10 ℃ ℃, Inlet water temp:26 ℃/28 ℃

2.SPECIFICATION

2.1 Performance data of Swimming Pool Heat Pump Unit

REFRIGERANT : R410A

UNIT		78546
Nominal Heating Capacity(85Hz)	kW	24.2
	Btu/h	82280
Range	kW	5.7~24.2
	Btu/h	19380~82280
*Nominal Heating Power Input(85Hz)	kW	4.8
*Range	kW	0.46~4.8
*Nominal Running Current Input(85Hz)	A	20.9
*Range	A	2.2~20.9
**Nominal Heating Capacity(85Hz)	kW	19.9
	Btu/h	67660
**Range	kW	4.68~19.9
	Btu/h	15912~67660
**Nominal Heating Power Input(85Hz)	kW	4.74
**Range	kW	0.72~4.74
**Nominal Running Current Input(85Hz)	A	20.6
**Range	A	3.5~20.6
***Nominal Heating Capacity(85Hz)	kW	17.8
	Btu/h	60520
***Range	kW	4.2~17.8
	Btu/h	14280~60520
***Nominal Heating Power Input(85Hz)	kW	4.4
***Range	kW	0.75~4.4
***Nominal Running Current Input(85Hz)	A	19.2
***Range	A	3.6~19.2
Power Supply		220-240-/50Hz
Compressor Quantity		1
Compressor		rotary
Fan Quantity		2
Fan Power Input	W	200
Fan Rotate Speed	RPM	400-800
Fan Direction		horizontal
Noise	dB(A)	46-57
Water Connection	mm	50
Water Flow Volume	m ³ /h	8.6
Water Pressure Drop(max)	kPa	11
Unit Net Dimensions(L/W/H)	mm	See the drawing of the units
Unit Ship Dimensions(L/W/H)	mm	See package lable
Net Weight	kg	see nameplate
Shipping Weight	kg	see package label

Rated Heating: Outdoor air temp: °C °C, Inlet water temp:26 °C/28 °C
 °COutdoor air temp: 15 °C °C, Inlet water temp:26 °C/28 °C
 Outdoor air temp: 10 °C °C, Inlet water temp:26 °C/28 °C

2.SPECIFICATION

2.1 Performance data of Swimming Pool Heat Pump Unit

REFRIGERANT : R410A

UNIT		78547
Nominal Heating Capacity(85Hz)	kW	28.3
	Btu/h	96220
Range	kW	6.7~28.3
	Btu/h	22780~96220
*Nominal Heating Power Input(85Hz)	kW	5.57
*Range	kW	0.54~5.57
*Nominal Running Current Input(85Hz)	A	9.29
*Range	A	1.13~9.29
**Nominal Heating Capacity(85Hz)	kW	23.3
	Btu/h	79220
**Range	kW	5.46~23.3
	Btu/h	18564~79220
**Nominal Heating Power Input(85Hz)	kW	5.49
**Range	kW	0.83~5.49
**Nominal Running Current Input(85Hz)	A	9.27
**Range	A	1.72~9.27
***Nominal Heating Capacity(85Hz)	kW	20.8
	Btu/h	70720
***Range	kW	4.9~20.8
	Btu/h	16660~70720
***Nominal Heating Power Input(85Hz)	kW	5.1
***Range	kW	0.87~5.1
***Nominal Running Current Input(85Hz)	A	9.01
***Range	A	1.81~9.01
Power Supply		380V/3N~/50Hz
Compressor Quantity		1
Compressor		rotary
Fan Quantity		2
Fan Power Input	W	200
Fan Rotate Speed	RPM	400-850
Fan Direction		horizontal
Noise	dB(A)	48-58
Water Connection	mm	50
Water Flow Volume	m ³ /h	10.0
Water Pressure Drop(max)	kPa	15
Unit Net Dimensions(L/W/H)	mm	See the drawing of the units
Unit Ship Dimensions(L/W/H)	mm	See package lable
Net Weight	kg	see nameplate
Shipping Weight	kg	see package label

Rated Heating: Outdoor air temp: °C °C, Inlet water temp:26 °C/28 °C
 °COutdoor air temp: 15 °C °C, Inlet water temp:26 °C/28 °C
 Outdoor air temp: 10 °C °C, Inlet water temp:26 °C/28 °C

2.SPECIFICATION

2.2 The dimensions for Swimming Pool Heat Pump Unit

78542/78543

unit:mm

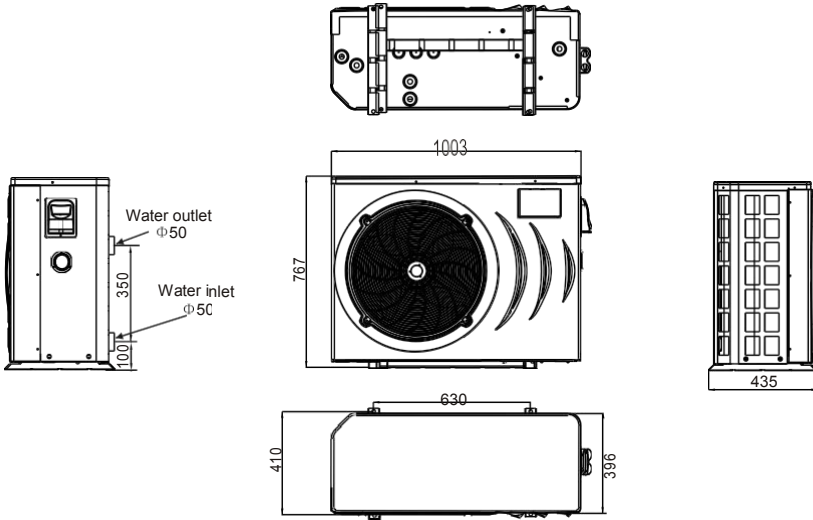

78544/78545

unit:mm

Model	78544	78545
A	400	470

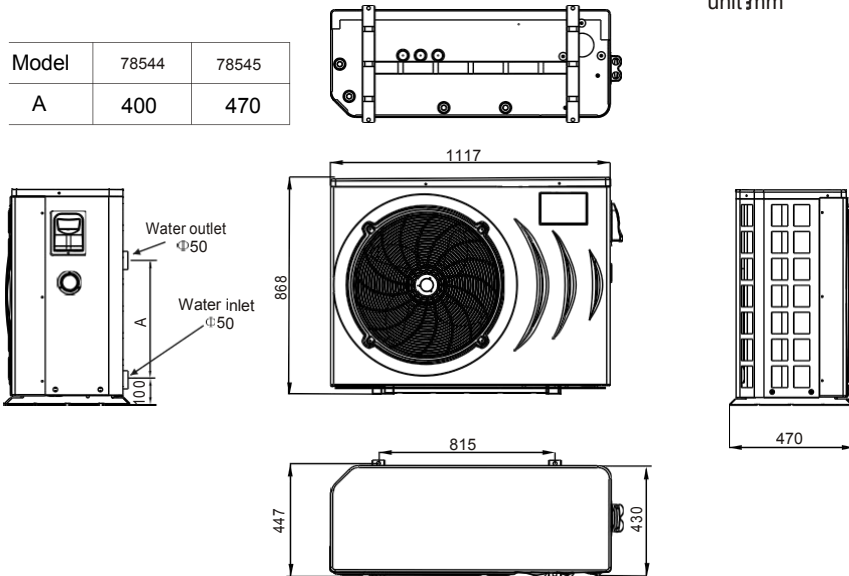

2.SPECIFICATION

2.2 The dimensions for Swimming Pool Heat Pump Unit

78546/78547

unit: mm

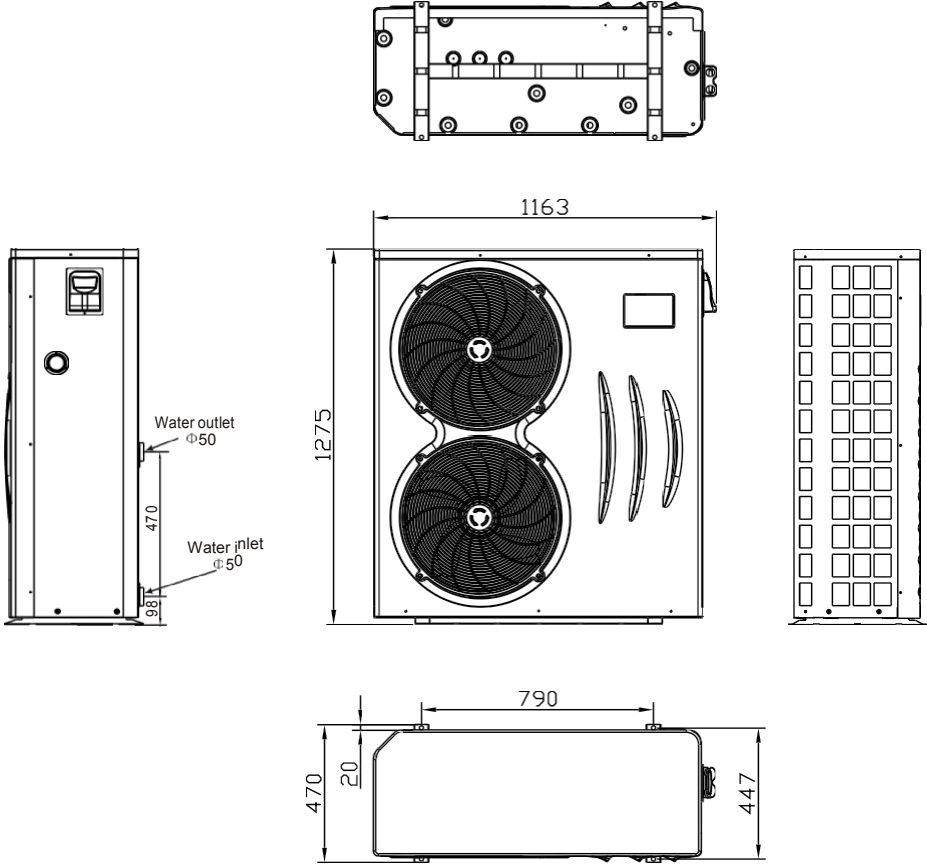

3.INSTALLATION AND CONNECTION

3.1 Installation illustration

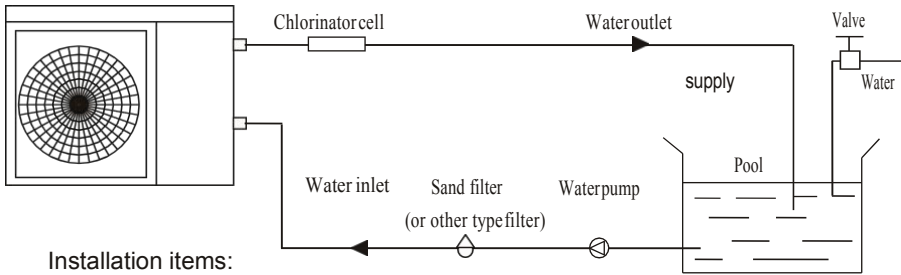

Installation items:

The factory only provides the main unit and the water unit; the other items in the illustration are necessary spare parts for the water system, that are provided by users or the installer.

Attention:

1. Open valve and charge water.
 2. Make sure that the pump and the water-in pipe have been filled with water.
 3. Close the valve and start the unit.
- ATTN: It is necessary that the water-in pipe is higher than the pool surface.

3.2 Swimming Pool Heat Pumps Location

The unit will perform well in any outdoor location provided that the following three factors are presented:

1. Fresh Air
2. Electricity
3. Pool filter piping

The unit may be installed virtually anywhere outdoors. For indoor pools please consult the supplier. Unlike a gas heater, it has no draft or pilot light problem in a windy area.

DO NOT place the unit in an enclosed area with a limited air volume, where the units discharge air will be re-circulated.

DO NOT place the unit to shrubs which can block air inlet. These locations deny the unit of a continuous source of fresh air which reduces its efficiency and may prevent adequate heat delivery.

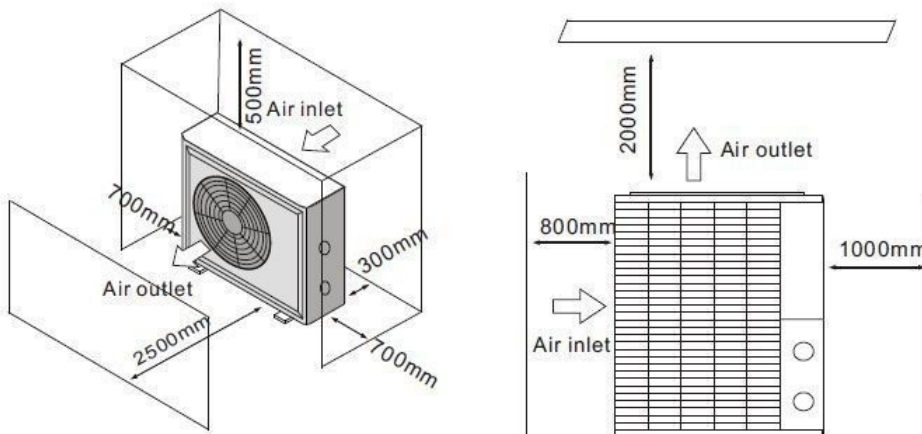

3.3 How Close To Your Pool?

Normally, the pool heat pump is installed within 7.5 meters of the pool. The longer the distance from the pool, the greater the heat loss from the piping. For the most part the piping is buried. Therefore, the heat loss is minimal for runs of up to 15 meters (15 meters to and from the pump = 30 meters total), unless the ground is wet or the water table is high. A very rough estimate of heat loss per 30 meters is 0.6 kW-hour, (2000BTU) for every 5 °C difference in temperature between the pool water and the ground surrounding the pipe, which translates to about 3% to 5% increase in run time.

3.INSTALLATION AND CONNECTION

3.4 Swimming Pool Heat Pumps Plumbing

The Swimming Pool Heat Pumps exclusive rated flow titanium heat exchanger requires no special plumbing arrangements except by-pass(please set the flow rate according to the nameplate). The water pressure drop is less than 10kPa at max. Flow rate. Since there is no residual heat or flame Temperatures, The unit does not need copper heat sink piping. PVC pipe can be run straight into the unit.

Location: Connect the unit in the pool pump discharge (return) line downstream of all filter and pool pumps, and upstream of any chlorinators, ozonators or chemical pumps.

Standard model have slip glue fittings which accept 40mm NB PVC pipe for connection to the pool or spa filtration piping. By using a 50 NB to 40NB you can plumb 50NB PVC piping straight into the unit.

Give serious consideration to adding a quick coupler fitting at the unit inlet and outlet to allow easy draining of unit for winterizing and to provide easier access should servicing be required.

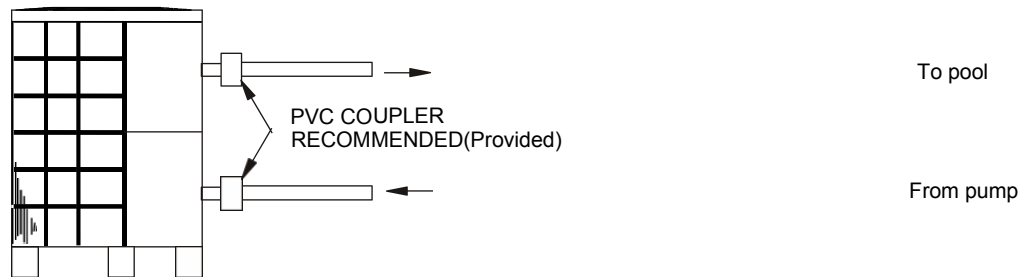

Condensation: Since the Heat pump cools down the air about 4 , water may condense on the fins of the horseshoe shaped evaporator. If the relative humidity is very high, this could be as much as several liters an hour. The water will run down the fins into the base pan and drain out through the barbed plastic condensation drain fitting on the side of the base pan.

This fitting is designed to accept 3/4" clear vinyl tubing which can be pushed on by hand and run to a suitable drain. It is easy to mistake the condensation for a water leak inside the unit.

NB: A quick way to verify that the water is condensation is to shut off the unit and keep the pool pump running. If the water stops running out of the base pan, it is condensation. AN EVEN QUICKER WAY IS TO TEST THE DRAIN WATER FOR CHLORINE - if there is no chlorine present, then it's condensation.

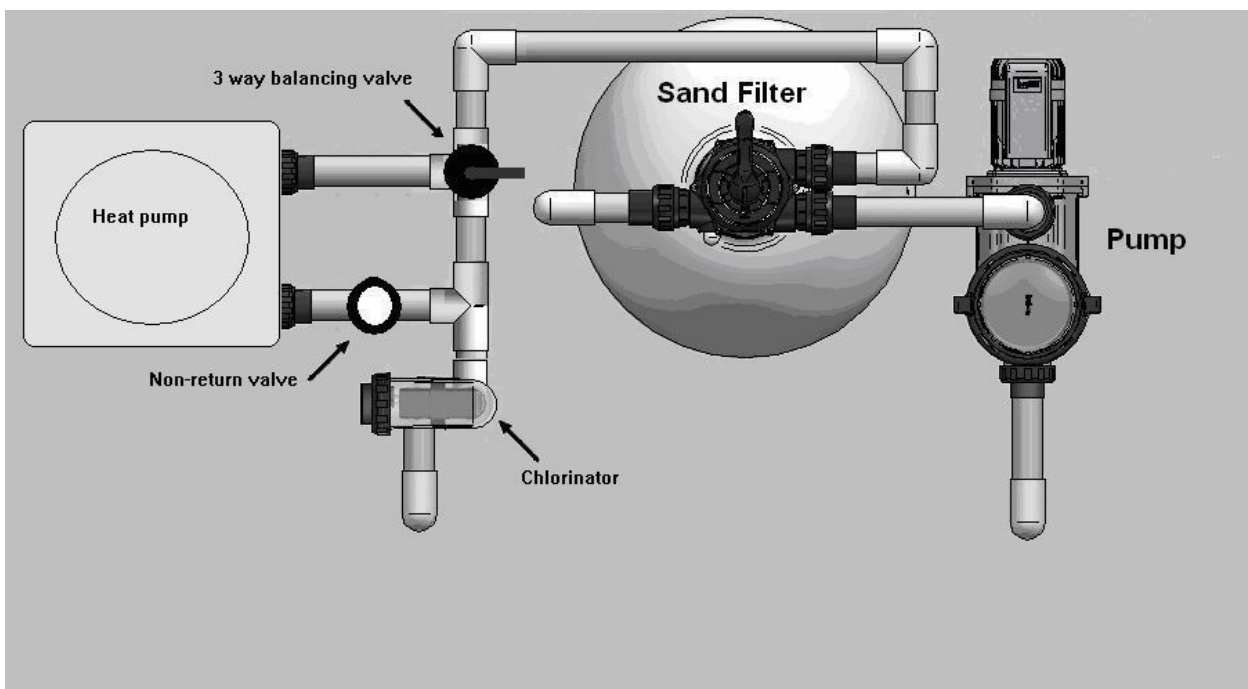

3.INSTALLATION AND CONNECTION

WATER CONNECTIONS

Where the heat pump is installed in the filtration circuit, the heater should always be installed after the pump and filter. The water connections are located on the right hand side of the heater. The inlet and outlet are clearly marked. Water connections supplied are for 50mm PVC glue in plumbing.

All automatic sanitising devices must be installed after the heater and in such a way that the sanitiser cannot enter the heater without first mixing with the water in the pool or spa. Sanitisers that are connected prior to the heater will void heater warranty.

The Astral Pool Heat Pump Pool Heater is only suitable for outdoor installation.

3.INSTALLATION AND CONNECTION

3.5 Swimming Pool Heat Pumps Electrical Wiring

NOTE: Although the unit heat exchanger is electrically isolated from the rest of the unit, it simply prevents the flow of electricity to or from the pool water. Grounding the unit is still required to protect you against short circuits inside the unit. Bonding is also required.

The unit has a separate molded-in junction box with a standard electrical conduit nipple already in place. Just remove the screws and the front panel, feed your supply lines in through the conduit nipple and wire-nut the electric supply wires to the three connections already in the junction box (four connections if three phase). To complete electrical hookup, connect Heat Pump by electrical conduit, UF cable or other suitable means as specified (as permitted by local electrical authorities) to a dedicated AC power supply branch circuit equipped with the proper circuit breaker, disconnect or time delay fuse protection.

Disconnect - A disconnect means (circuit breaker , fused or un-fused switch) should be located within sight of and readily accessible from the unit, This is common practice on commercial and residential air conditioners and heat pumps. It prevents remotely-energizing unattended equipment and permits turning off power at the unit while the unit is being serviced.

3.6 Initial startup of the Unit

NOTE- In order for the unit to heat the pool or spa, the filter pump must be running to circulate water through the heat exchanger.

Start up Procedure - After installation is completed, you should follow these steps:

1. Turn on your filter pump. Check for water leaks and verify flow to and from the pool.
2. Turn on the electrical power supply to the unit, then press the key ON/OFF of wire controller, It should start in several seconds.
3. After running a few minutes make sure the air leaving the top(side) of the unit is cooler(Between 5-10 °C)
4. With the unit operating turn the filter pump off. The unit should also turn off automatically,
5. Allow the unit and pool pump to run 24 hours per day until desired pool water temperature is reached. When the water-in temperature reach setting, The unit just shuts off. The unit will now automatically restart (as long as your pool pump is running) when the pool temperature drops more than 2 below set temperature.

Time Delay- The unit is equipped with a 3 minute built-in solid state restart delay included to protect control circuit components and to eliminate restart cycling and contactor chatter.

This time delay will automatically restart the unit approximately 3 minutes after each control circuit interruption. Even a brief power interruption will activate the solid state 3 minute restart delay and prevent the unit from starting until the 5 minute countdown is completed. Power interruptions during the delay period will have no effect on the 3 minute countdown.

GUIDE TO HEAT PUMP NOISE

Determining Distance to Neighbour's Boundary

Heat Pumps are designed for slow heat up times and maintenance heating. The limitation of power supply in nearly all residential homes means that a Heat Pump's maximum size for most homes is about 6 hp. A unit of this size will typically generate around 25 kW of pool heating at maximum efficiency. For most swimming pools, this means the Heat Pump will operate for 2 or 3 days continuously for the initial heat up period and then between 12 and 24 hours each day to maintain the swimming pool temperature.

Heat Pumps are very similar to air conditioners. An evaporator fan and compressor operate during their "on" time and as the "on" time can be 12 to 24 hours per day, care must be taken to locate the Heat Pump so that the noise produced during its operation does not interfere with sensitive areas - not only in your own home but in your neighbour's home.

Each State in Australia has municipal, state and EPA laws which govern the installation and operation of outdoor appliances in residential areas. In general, noise from an appliance such as a Heat Pump must not unreasonably interfere with the health, welfare, convenience, comfort and amenity of any person having regard to the nature and duration of the noise emission and the time of day at which the noise is emitted.

Criteria for noise emissions generally take into account back ground noise at the time of day, but the most stringent criteria applies at night – and take into account, the Heat Pump will most likely need to operate at night during cooler months of the year to maintain the pool temperature.

This guide provides an estimate only and should not be taken as definite advice on the location and installation of your Heat Pump. Should any doubt exist, seek advice from an Acoustical Consultant which can be found in the Yellow Pages.

The ASTRAL POOL Heat Pump has a sound power level of 66 dB(A) at 1 metre distance. The following factors should be taken into account when working out where to locate the Heat Pump.



$$\boxed{66 \text{ dB(A)}} - \boxed{\text{Barrier Factor}}_{\text{BOX 1}} + \boxed{\text{Reflection Factor}}_{\text{BOX 2}} = \boxed{\text{Distance Factor}}_{\text{BOX 3}}$$

3.INSTALLATION AND CONNECTION

Barrier: A fence or barrier can reduce the level of the Heat Pump's noise heard in neighbouring premises. To do this, the barrier or fence needs to be continuous with few or no gaps and go down to ground level. It must also prevent the Heat Pump from being seen from noise sensitive locations on neighbouring premises. Noise sensitive locations include bedroom and living room windows (including second storey dwellings) and outdoor entertaining/relaxing areas.

Factor for box 1

Carefully read through the fence/barrier descriptions below. Select a value that corresponds to the fence/barrier description applicable to your situation. Put this value in Box 2 above.

		  1
1	The fence/barrier does not prevent the Heat Pump from being seen from noise sensitive locations on neighbouring properties	0
2	The fence/barrier blocks line of sight but is made of material having large gaps, such as a picket fence, or brick wall with openings or fancy inserts.	0
3	The fence/barrier blocks line of sight of the Heat Pump from noise sensitive location eg: Typical paling fence with small gaps due to warping.	5
4	The fence/barrier blocks line of sight of the Heat Pump from noise sensitive location e.g. "Colorbond" fencing, concrete block/masonry/brick, Fibre cement sheeting	0

Reflection factor

Noise can reflect from walls, roofs, sheds etc. This can have the effect of making the noise seem louder than what it is. Put the corresponding value in Box 3.

Factor for BOX 2

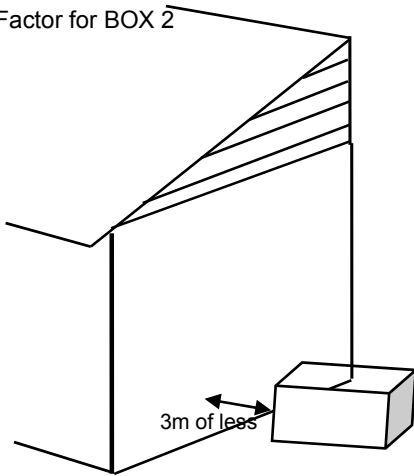

One reflective surface
Value for BOX 3 = 3

2 reflective surface
Value for BOX 3 = 6

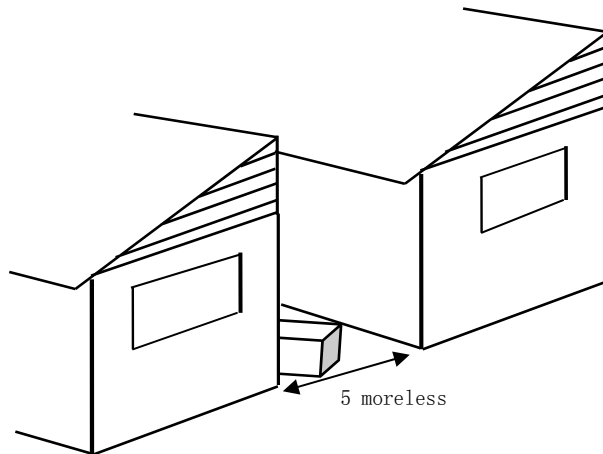
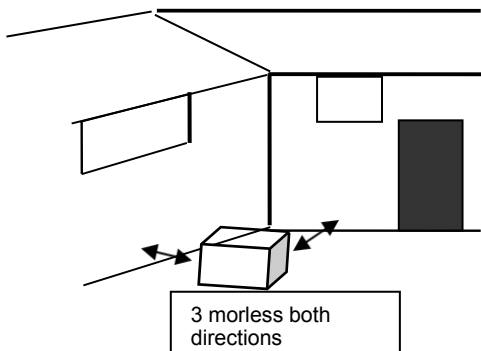

3.INSTALLATION AND CONNECTION

Distance Factor

An example may look like this:

A Timber Paling fence that goes right to the ground with some small gaps due to age, is worth a barrier factor of 5.

One reflective surface adjacent to the Heat Pump is worth a factor of 3.

The ASTRAL POOL Heat Pump has a sound power level of 66 db(A).

Therefore your equation will now look like this:

$$\begin{array}{rcccccc} 60 \text{ dbA} & & - & 5 & + & 3 & = & 8 \\ \text{Heat pump sound} & & & \text{Barrier factor} & & \text{Reflective} & & \text{distance factor} \\ \text{pressure level} & & & & & \text{surface} & & \end{array}$$

The distance factor is 58 which should be written in Box 3.

The final step is to mark 64 on Column 2 below and draw a straight line through the middle X to reach Column 1. Column 1 is the minimum distance the Heat Pump should be installed from a noise sensitive area in your neighbour's residence.

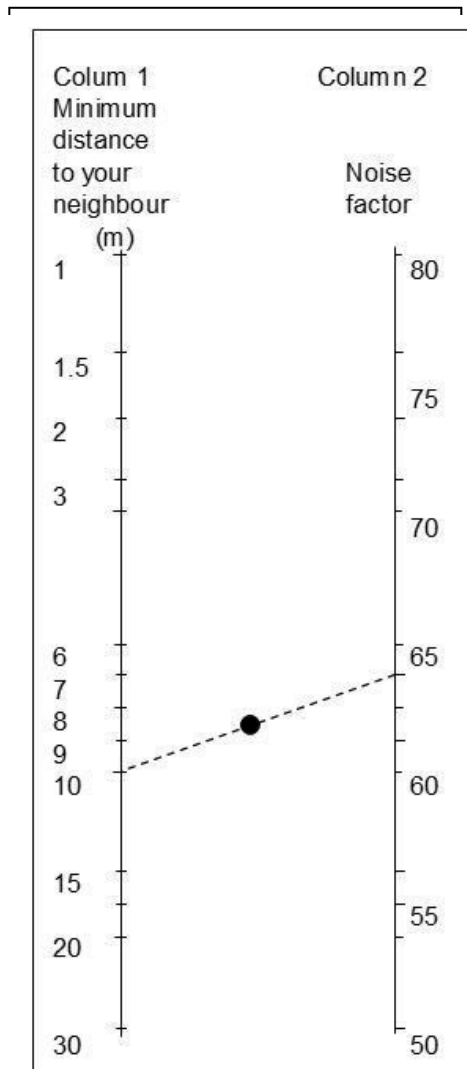

With one reflective surface and a timber paling fence with small gaps, the Heat Pump needs to be installed at least 10 metres from a noise sensitive area in your neighbour's property.

This calculation is intended as a guide only and no warranty is made or implied by Astral Pool as to its accuracy. Please consult an Acoustical Consultant or phone your Astral Pool branch office if in any doubt.

Operation and use

1. Color screen wire controller interface introduction

1.1 Main interface

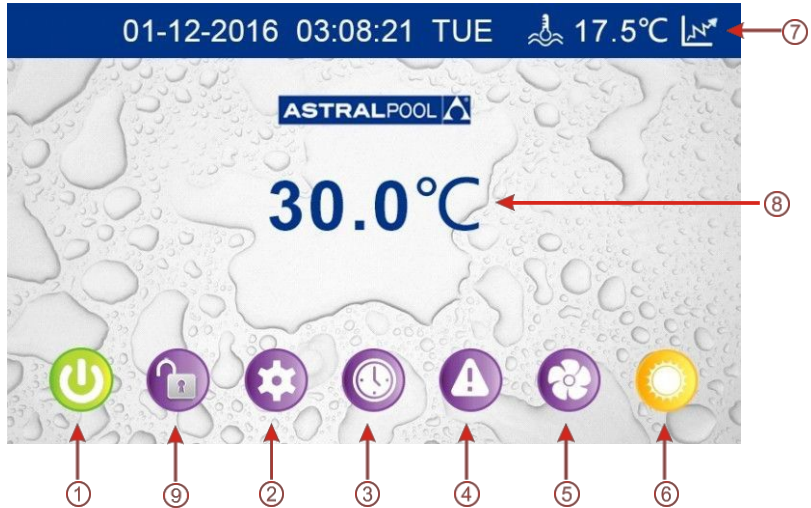

1.2 Button Description

NO.	Name	The button function
①	ON/OFF	Press to start /shut off the unit
②	Parameter	Click this button to view the unit state and the parameter
③	CLOCK	Press to set the clock, the timer on or timer off
④	Fault display	Click to view fault history
⑤	Silent setting	Click to turn on/off silent function and to set timingLow speed function.
⑥	MODE	Click to enter the mode switch interface
⑦	Temp.curve	Click to view the temp. and power curve
⑧	Water Inlet Temp.	Click to enter mode setting and the target temp. Setting interface
⑨	LOCK	Click to lock the screen Input "22" to unlock the screen by press the "lock button"

2. Color screen wire controller function introduction

2.1 Booting and shutdown

As shown in figure 1.1:

In shutdown status, click ① then the unit will be booted

In booting status, click ① then the unit will be shut down.

2.2 Mode switch and target temperature Setting

2.2 1 Mode switch

In the main interface, click mode button or inlet water temperature setting button, interface displays as follows:

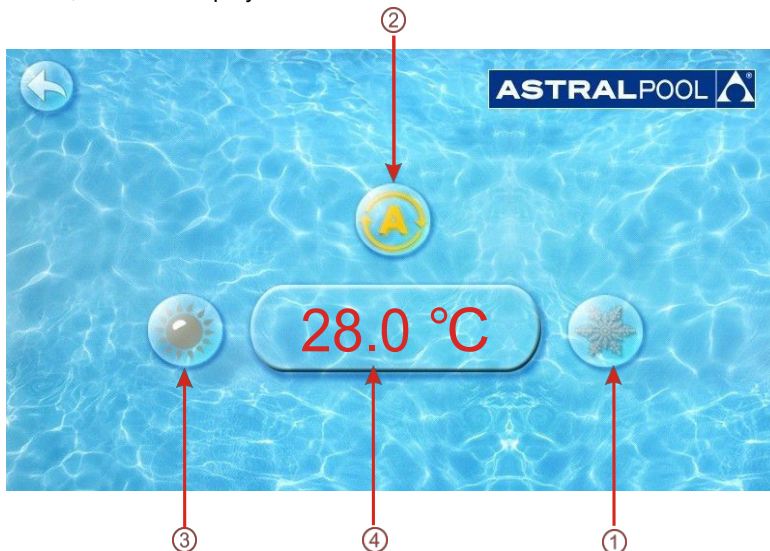

Click the refrigeration mode button ①, automatic mode ② or heating mode button ③ then you can select the corresponding mode.

Note: when the unit is designed for single automatic mode or single thermal mode, the mode can not be switched.

2.2 2 Target temp. setting

Click the temperature set button ④, you can set the target temperature.

2.3 Clock setting

In the main interface, click on the clock Settings button, interface displays as follows:



23.1 The operation of time setting

Click on the time Settings button ① , interface displays as follows:

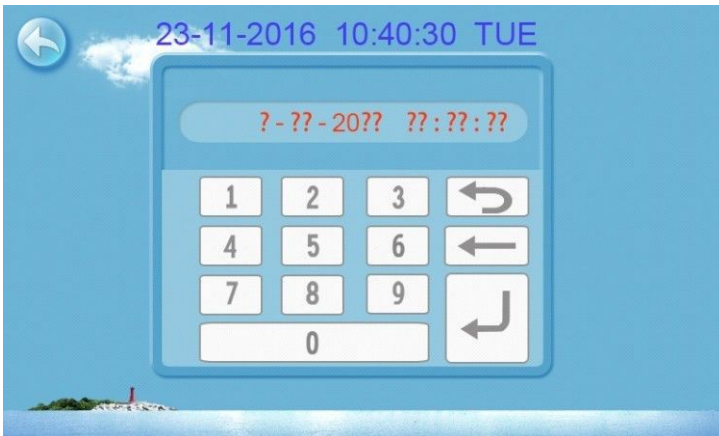

Click the value to set time directly, the click confirm button to save the Settings.

For example: setup time: the 30-11-2016 16:00:00, input 30 11 16 16 00 00 , the time change then click confirm button.

Note: if the input format is not correct, the wrong time will be saved by clicking confirm button.

Operation and use

2.32 The operation of timing setting

Click the timing set button ② timing set interface.

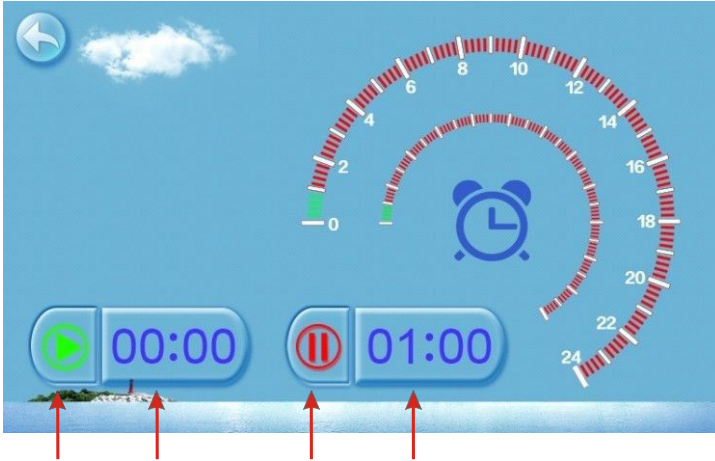

NO.	Name	Button color	Button function
①	Timing start button	Start: green End: gray	Click this button to start or end timing start setting function
②	Timing on setting		Click to set start time of the timing
③	Timing end button	Open: red End: gray	Click this button to start or end timing end setting function
④	Timing off setting		Click to set end time of the timing

For example above: without action, 0 o'clock and 1 o'clock will be the on and off time of timing settings.

Operation and use

2.4 Silent setting and silent timing setting

Click the silent setting button ,and the interface displays as follows:



2.4.1 The silent button

Click the silent button ①, the unit will enter the silent mode, and interface displays as follows:



Click the silent button ① again, to exit the silent mode.

Operation and use

2.4.2 Timing silent function setting

Click timing silent button ②, and interface displays as follows:

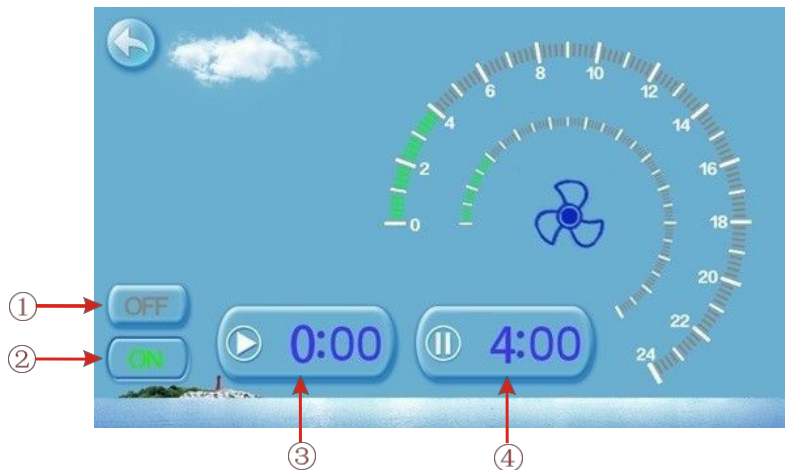

NO.	Name	Color	Function
①	Timing silent off	Used:red Unused:gray	Click to use or unuse timing off function
②	Timing silent on	Use:green Unused:gray	Click to use or unuse timing on function
③	Timing silent start time		Click this button to set the timing silent start time
④	Timing silent end time		Click this button to set the timing silent end time

Start time and end time setting value must be among the range of 0:00-23:00, and setting value can be precise to hour digit.



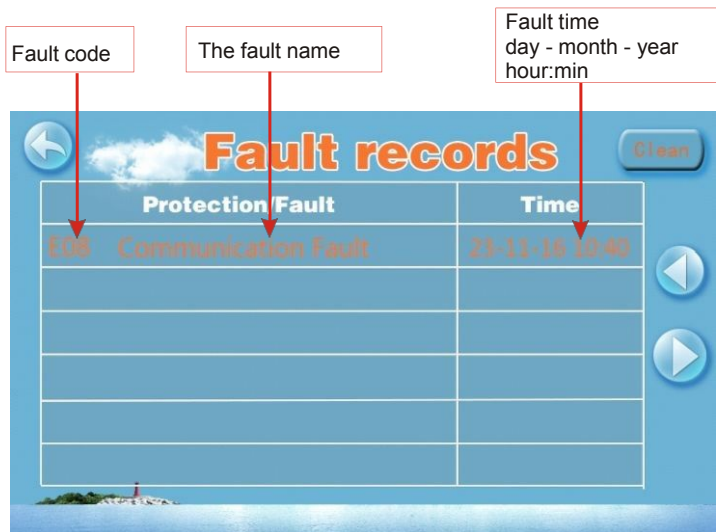

For example above, click "ON" to use timing silent, the unit will start the silent at 0:00 points and end at 4:00; click "OFF" to unuse the timing silent, but if the unit is in timing silent mode, it will exit silent timing immediately.

2.5 History of the fault

In the main interface click fault display key, interface displays as follows:



If no failure, main interface displays static 

When fault occurs, the fault icon will flash  between the " " " ", the failure interface will record time, code, name of the  fault.

After troubleshooting, if you do not check the failure record,

the main interface will display static "; if you check the

failure record, the main interface will display static ";

Failure record is in reverse order, according to the happening time.

Press the "Clean" key, you can delete the fault record.

2.6 Temperature curve

In the main interface, click the curve display button, interface displays as follows:

2.6.1 Temperature recording curve is as follows:



2.6.2 The average power curve



Temperature curve automatically updates every one hour, and the curve record can be stored for 60 days;

Start from the latest curve saved time, if power is off and curve datacollecting time is less than one hour,the data in this period will not be saved;

3.INSTALLATION AND CONNECTION

Further Guidelines for installation of Heat Pumps

- ASTRAL POOL Heat Pumps must be installed outdoors – never install inside a plant room, garage etc.
- Allow a minimum of 500mm clearance from the sides and rear of the heat pump and a minimum of 1000mm service access from the front of the HeatPump.
- Ensure an electrical isolation switch is located nearby the HeatPump.
- On Three Phase models, ensure the phase rotation of the compressor is checked before commissioning of the unit.
- Ensure the water pressure switch operation is checked at least 6 times prior to handing over the Heat Pump.
- Refer to Installation and Operating Instructions for full installation, commissioning and operating procedures.

3 .Parameter list and breakdown table

3.1 Electronic control fault table

Can be judged according to the remote controller failure code and troubleshooting

Protect/fault	Fault display	Reason	Elimination methods
standby	Non		
Normal boot	Non		
Inlet Temp. Sensor Fault	P01	The temp. Sensor is broken or short circuit	Check or change the temp. Sensor
Outlet Temp. Sensor Fault	P02	The temp. Sensor is broken or short circuit	Check or change the temp. Sensor
Ambient Temp. Sensor Fault	P04	The temp. Sensor is broken or short circuit	Check or change the temp. Sensor
Coil Temp. Sensor Fault	P05	The temp. Sensor is broken or short circuit	Check or change the temp. Sensor
Suction Temp. Sensor Fault	P07	The temp. Sensor is broken or short circuit	Check or change the temp. Sensor
Discharge Temp. Sensor Fault	P081	The temp. Sensor is broken or short circuit	Check or change the temp. Sensor
High Pressure Prot.	E01	The high-pressure switch is broken	Check the pressure switch and cold circuit
Low Pressure Prot.	E02	Low pressure1 protection	Check the pressure switch and cold circuit
Flow Switch Prot.	E03	No water/little water in water system	Check the pipe water flow and water pump
Anti-freezing Prot	E07	Water flow is not enough	Check the pipe water flow and whether water system is jammed or not
Primary Anti-freezing Prot.	E19	The ambient temp. is low	
Secondary Anti-freezing Prot.	E29	The ambient temp. is low	
Inlet and outlet temp. too big	E06	Water flow is not enough and low differential pressure	Check the pipe water flow and whether water system is jammed or not
Low temperature protection	Non	The environment temp. is low	
Comp. Overcurrent Prot.	E051	The compressor is overload	Check whether the system of the compressor running normally
Exhaust Air over Temp Prot.	P082	The compressor is overload	Check whether the system of the compressor running normally
Communication Fault	E08	Communication failure between wire controller and mainboard	Check the wire connection between remote wire controller and main board
Antifreeze Temp. Sensor Fault	P09	antifreeze temp sensor is broken or short circuited	check and replace this temp sensor
Waterway Anti-freezing Prot.	E05	water temp.or ambient temp. is too low	
EC fan feedback Fault	F051	There is something wrong with fan motor and fan motor stops running	Check whether fan motor is broken or locked or not
Pressure sensor Fault	PP	The pressure Sensor is broken	Check or change the pressure Sensor or pressure

Frequency conversion board fault table:

Protection/fault	Fault display	Reason	Elimination methods
Drv1 MOP alarm	F01	MOP drive alarm	Recovery after the 150s
Inverter offline	F02	Frequency conversion board and main board communication failure	Check the communication connection
IPM protection	F03	IPM modular protection	Recovery after the 150s
Comp. Driver Failure	F04	Lack of phase, step or drive hardware damage	Check the measuring voltage check frequency conversion board hardware
DC Fan Fault	F05	Motor current feedback open circuit or short circuit	Check whether current return wires connected motor
IPM Overcurrent	F06	IPM Input current is large	Check and adjust the current measurement
Inv. DC Overvoltage	F07	DC bus voltage > Dc bus over-voltage protection value	Check the input voltage measurement
Inv. DC Lessvoltage	F08	DC bus voltage < Dc bus over-voltage protection value	Check the input voltage measurement
Inv. Input Lessvolt.	F09	The input voltage is low, causing the input current is high	Check the input voltage measurement
Inv. Input Overvolt.	F10	The input voltage is too high, more than outage protection current RMS	Check the input voltage measurement
Inv. Sampling Volt.	F11	The input voltage sampling fault	Check and adjust the current measurement
Comm. Err DSP-PFC	F12	DSP and PFC connect fault	Check the communication connection
Input Over Cur.	F26	The equipment load is too large	
PFC fault	F27	The PFC circuit protection	Check the PFC switch tube short circuit or not
IPM Over heating	F15	The IPM module is overheat	Check and adjust the current measurement
Weak Magnetic Warn	F16	Compressor magnetic force is not enough	
Inv. Input Out Phase	F17	The input voltage lost phase	Check and measure the voltage adjustment
IPM Sampling Cur.	F18	IPM sampling electricity is fault	Check and adjust the current measurement
Inv. Temp. Probe Fail	F19	Sensor is short circuit or open circuit	Inspect and replace the sensor
Inverter Overheating	F20	The transducer is overheat	Check and adjust the current measurement
Inv. Overheating Warn	F22	Transducer temperature is too high	Check and adjust the current measurement
Comp. OverCur. Warn	F23	Compressor electricity is large	The compressor over-current protection
Input Over Cur. Warn	F24	Input current is too large	Check and adjust the current measurement
EEPROM Error Warn	F25	MCU error	Check whether the chip is damaged Replace the chip
V15V over/undervoltage fault	F28	The V15V is overload or undervoltage	Check the V15V input voltage in range 13.5v~16.5v or not

Operation and use

3.2 Parameter list

Meaning	Default	Remarks
Refrigeration target temperature set point	27 °C	Adjustable
Heating the target temperature set point	27 °C	Adjustable
Automatic target temperatureset point	27 °C	Adjustable

4. Interface drawin

4.1 Wire control interface diagram and definition

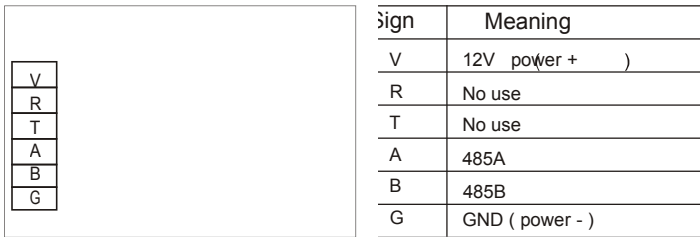

4.2 Controller interface diagram and definition

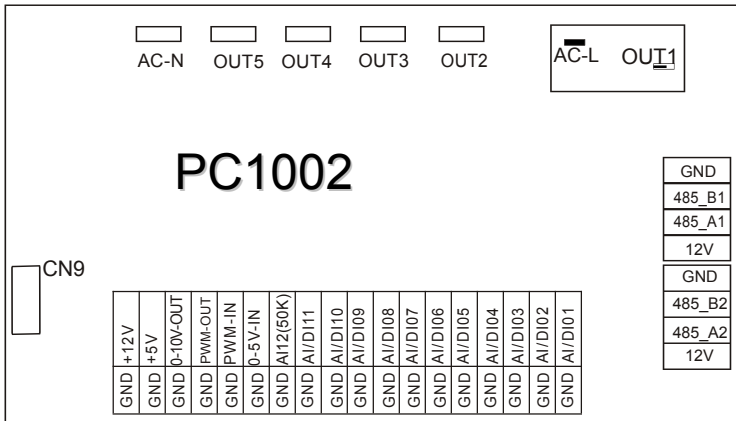

Operation and use

Main board of the input and output interface instructions below

Number	Sign	Meaning
01	OUT1	Compressor (output 220-230VAC)
02	OUT2	Water pump (output 220-230VAC)
03	OUT3	4-way valve(output 220-230VAC)
04	OUT4	High speed of fan (output 220-230VAC)
05	OUT5	Low speed of fan (output 220-230VAC)
06	AC-L	Live wire (input 220-230VAC)
07	AC-N	Neutral wire (input 220-230VAC)
08	AI/DI01	Emergency switch (input)
09	AI/DI02	Water flow switch (input)
10	AI/DI03	System low pressure (input)
11	AI/DI04	System high pressure (input)
12	AI/DI05	System suction temperature (input)
13	AI/DI06	Water input temperature (input)
14	AI/DI07	Water output temperature (input)
15	AI/DI08	System fan coil temperature (input)
16	AI/DI09	Ambient temperature (input)
17	AI/DI10	Mode switch (input)
18	AI/DI11	Master-slave machineswitch / Antifreeze temperature (input)
19	A12(50K)	System Exhaust temperature (input)
20	0_5V_IN	Compressor current detection/Pressure sensor(input)
21	PWM_IN	Master-slave machineswitch / Feedback signal of EC fan (input)
22	PWM_OUT	AC fan control output
23	0_10V_OUT	EC fan control output
24	+5V	+5V (output)
25	+12V	+12V (output)
26	GND	Frequency conversion board communications
27	485_B1	
28	485_A1	
29	12V	
30	GND	Color line controller communication
31	485_B2	
32	485_A2	
33	12V	
34	CN9	Electronic expansion valve

5. MAINTENANCE AND INSPECTION

- Check the water supply device and the release often. You should avoid the condition of no water or air entering into system, as this will influence unit's performance and reliability. You should clear the pool/spa filter regularly to avoid damage to the unit as a result of the dirty of clogged filter.
- The area around the unit should be dry, clean and well ventilated. Clean the side heating exchanger regularly to maintain good heat exchange as conserve energy .
- The operation pressure of the refrigerant system should only be serviced by a certified technician .
- Check the power supply and cable connection often,.Should the unit begin to operate abnormally, switch it off and contact the qualified technician.
- Discharge all water in the water pump and water system ,so that freezing of the water in the pump or water system does not occur. You should discharge the water at the bottom of water pump if the unit will not be used for an extended period of time. You should check the unit thoroughly and fill the system with water fully before using it for the first time after a

6.APPENDIX

6.1 Caution & Warning

1. The unit can only be repaired by qualified installer centre personnel or an authorised dealer. (for Europe market)
2. This appliance is not intended for use by persons (including children) with reduced physical sensory or mental capabilities, or lack of experience and knowledge, unless they have been given supervision or instruction concerning use of the appliance by a person responsible for their safety. (for Europe market)
Children should be supervised to ensure that they do not play with the appliance.
3. Please make sure that the unit and power connection have good earthing, otherwise may cause electrical shock.
4. If the supply cord is damaged, it must be replaced by the manufacturer or our service agent or similarly qualified person in order to avoid a hazard.
5. Directive 2002/96/EC (WEEE):
The symbol depicting a crossed-out waste bin that is underneath the appliance indicates that this product, at the end of its useful life, must be handled separately from domestic waste, must be taken to a recycling centre for electric and electronic devices or handed back to the dealer when purchasing an equivalent appliance.
6. Directive 2002/95/EC (RoHs): This product is compliant with directive 2002/95/EC (RoHs) concerning restrictions for the use of harmful substances in electric and electronic devices.
7. The unit CANNOT be installed near the flammable gas. Once there is any leakage of the gas, fire can occur.
8. Make sure that there is circuit breaker for the unit, lack of circuit breaker can lead to electrical shock or fire.
9. The heat pump located inside the unit is equipped with an over-load protection system. It does not allow for the unit to start for at least 3 minutes from a previous stoppage.
10. The unit can only be repaired by the qualified personnel of an installer center or an authorized dealer. (for North America market)
11. Installation must be performed in accordance with the NEC/CEC by authorized person only. (for North America market)
12. USE SUPPLY WIRES SUITABLE FOR °C.
13. Caution: Single wall heat exchanger, not suitable for potable water connection.

6.APPENDIX

6.2 Cable specification

(1) Single phase unit

Nameplate maximum current	Phase line	Earth line	MCB	Creepage protector	Signal line
No more than 10A	$2 \times 1.5\text{mm}^2$	1.5mm^2	20A	30mA less than 0.1 sec	$n \times 0.5\text{mm}^2$
10~16A	$2 \times 2.5\text{mm}^2$	2.5mm^2	32A	30mA less than 0.1 sec	
16~25A	$2 \times 4\text{mm}^2$	4mm^2	40A	30mA less than 0.1 sec	
25~32A	$2 \times 6\text{mm}^2$	6mm^2	40A	30mA less than 0.1 sec	
32~40A	$2 \times 10\text{mm}^2$	10mm^2	63A	30mA less than 0.1 sec	
40 ~63A	$2 \times 16\text{mm}^2$	16mm^2	80A	30mA less than 0.1 sec	
63~75A	$2 \times 25\text{mm}^2$	25mm^2	100A	30mA less than 0.1 sec	
75~101A	$2 \times 25\text{mm}^2$	25mm^2	125A	30mA less than 0.1 sec	
101~123A	$2 \times 35\text{mm}^2$	35mm^2	160A	30mA less than 0.1 sec	
123~148A	$2 \times 50\text{mm}^2$	50mm^2	225A	30mA less than 0.1 sec	
148~186A	$2 \times 70\text{mm}^2$	70mm^2	250A	30mA less than 0.1 sec	
186~224A	$2 \times 95\text{mm}^2$	95mm^2	280A	30mA less than 0.1 sec	

(2) Three phase unit

Nameplate maximum current	Phase line	Earth line	MCB	Creepage protector	Signal line
No more than 10A	$3 \times 1.5\text{mm}^2$	1.5mm^2	20A	30mA less than 0.1 sec	$n \times 0.5\text{mm}^2$
10~16A	$3 \times 2.5\text{mm}^2$	2.5mm^2	32A	30mA less than 0.1 sec	
16~25A	$3 \times 4\text{mm}^2$	4mm^2	40A	30mA less than 0.1 sec	
25~32A	$3 \times 6\text{mm}^2$	6mm^2	40A	30mA less than 0.1 sec	
32~40A	$3 \times 10\text{mm}^2$	10mm^2	63A	30mA less than 0.1 sec	
40 ~63A	$3 \times 16\text{mm}^2$	16mm^2	80A	30mA less than 0.1 sec	
63~75A	$3 \times 25\text{mm}^2$	25mm^2	100A	30mA less than 0.1 sec	
75~101A	$3 \times 25\text{mm}^2$	25mm^2	125A	30mA less than 0.1 sec	
101~123A	$3 \times 35\text{mm}^2$	35mm^2	160A	30mA less than 0.1 sec	
123~148A	$3 \times 50\text{mm}^2$	50mm^2	225A	30mA less than 0.1 sec	
148~186A	$3 \times 70\text{mm}^2$	70mm^2	250A	30mA less than 0.1 sec	
186~224A	$3 \times 95\text{mm}^2$	95mm^2	280A	30mA less than 0.1 sec	

When the unit will be installed at outdoor, please use the cable which can against UV.

WARRANTY TERMS AND CONDITIONS

AstralPool Australia Pty Ltd (ABN 97 007 284 504) ("AstralPool") provides the following warranty in relation to its Astralpool Heat Pump

Our goods come with guarantees that cannot be excluded under the Australian Consumer Law. You are entitled to a replacement or refund for a major failure and for compensation for any other reasonably foreseeable loss or damage. You are also entitled to have the goods repaired or replaced if the goods fail to be of acceptable quality and the failure does not amount to a major failure.

The benefits of this warranty are in addition to any rights and remedies imposed by Australian state and federal legislation that cannot be excluded. Nothing in this warranty is to be interpreted as excluding, restricting or modifying any state or federal legislation applicable to the supply of goods and services which cannot be excluded, restricted or modified.

WARRANTY

AstralPool warrants that, subject to the exclusions and limitations below, the product will be free from defects in materials and workmanship during the warranty period. The warranty periods are set out below and commence 30 days after the date of purchase (to allow for installation). The warranty period may vary for different parts of the Product.

Parts	Warranty Period
Cabinet, heat exchange	10 years
Compressor and evaporator	3 years
Thermostat, switches, and other components	12 months

If a defect appears in the product before the end of the warranty period and AstralPool finds the product to be defective in materials or workmanship, AstralPool will, in its sole discretion, either:

- (a) Replace or repair the product or the defective part of the product free of charge; or
- (b) Cause the product or the defective part of the product to be replaced or repaired by an authorised AstralPool Service Agent free of charge.

AstralPool reserves the right to replace defective parts of the product with parts and components of similar quality, grade and composition where an identical part or component is not available.

Goods presented for repair may be replaced by refurbished goods of the same type rather than being repaired. Refurbished parts may be used to repair the goods.

WARRANTY CLAIMS

1. If a fault covered by warranty occurs, the customer must first contact AstralPool at the contact address listed below, or an Authorised AstralPool Service Agent.
2. Any warranty claim must be accompanied by:
 - (a) Proof of purchase;
 - (b) Full details of the alleged defect; and
 - (c) Appropriate documentation (such as historical and maintenance records).
3. The customer must make the product available to AstralPool or its authorised AstralPool service agent for inspection and testing. AstralPool or its authorised AstralPool service agent will attend the premises where the product is installed for inspection and testing. If the product is installed:
 - (a) Outside a capital city metropolitan area; and
 - (b) Is not within a 20 km radius of an Authorised AstralPool Service Agent;

Then the customer may have to pay a travel fee.

4. If such inspection and testing finds no defect in the product, the customer must pay AstralPool's usual costs of service work and testing. If such inspection and testing finds a defect that is not covered by this warranty, the customer must pay AstralPool's usual costs of service work plus any parts and labour required to repair the Product, unless recoverable from AstralPool on the failure of any statutory guarantee under the ACL.

Exclusions

The warranty will not apply where:

- (a) The customer is in breach of the Terms and Conditions of Sale;
- (b) The Product was used for a purpose other than one it was intended for;
- (c) The Product was repaired, modified or altered by any person other than AstralPool;
- (d) The Product has not been installed, maintained and/or operated in complete compliance with the installation and operating instructions and any instructions by AstralPool;
- (e) The Product has been subject to accident, negligence, alteration, abuse or misuse.

The warranty does not extend to:

- a) Normal wear and tear;
- b) Weather and other environmental conditions including but not limited to storm, flood, and/or heat wave damage; or
- c) Service and maintenance items.
- d) Installations in countries outside of Australia and its associated territories

Examples of exclusions include but are not limited to:

- Incorrect/insufficient ventilation
- Incorrect water balance

Commercial Installations

On commercial installations, such as health clubs, motels/hotels and hydrotherapy facilities, the warranty is limited to parts and in field labour (within capital city metropolitan areas or 20 km radius of Authorised AstralPool Service Agents) for a period of 12 months from the date of purchase plus 30 days to allow for installation.

LIMITATIONS

AstralPool makes no express warranties or representations other than set out in this warranty.

The repair or replacement of the Product or part of the Product is the absolute limit of AstralPool's liability under this express warranty.

sales@astralpool.com.au
www.astralpool.com.au



facebook.com/astralpoolAU